



***Park Tool***

2014

# INDEX

- 57 Aprons/Apparel
- 31 Axle Vises
- 22 Backpacks
- 35-37 Bottom Bracket Tools
- 39-41 Brake Tools
- 43 Chain Cleaning & Measuring
- 44 Chain Tools
- 32 Chain Whips
- 42 Cleaning & Lubrication
- 31 Cone Wrenches
- 35 Crank Tools
- 58 Display Systems
- 45-52 Frame & Fork Tools
- 32 Freewheel/Cassette Removers
- 19-20 General Tools
- 51-52 Headset Tools
- 27-29 Hex Wrenches
- 31 Hub & Axle Tools
- 33 Measuring Tools
- 25-26 Multi-Tools
- 55-57 Park Tool Gear
- 2 Park Tool School
- 38 Pedal Tools
- 35 Pin Spanners
- 53 Portable Workbench
- 17-18 Pumps
- 3-8 Repair Stands
- 10 Repair Stand Accessories
- 9-10 Repair Stand Clamps & Parts
- 14 Spoke Wrenches
- 53-54 Storage
- 54 Storage Hooks
- 15-16 Tire Tools and Inner Tube Repair
- 21-24 Tool Kits
- 34 Torque Wrenches
- 30 Torx® Compatible Wrenches
- 13 Wheel Tools
- 11-12 Wheel Truing Stands



## www.parktool.com – Park Tool Web Site

www.parktool.com is considered by many to be the most useful site in the bicycle industry.

Detailed Product Information

Dealer Locator for Products and Programs

Extensive Repair Help Library

- Up to date specs and photos of our entire product line
- Exploded view drawings and part numbers for most Park Tool products
- Downloadable versions of this catalog in French, German, Spanish, Japanese, Italian, Chinese and English
- Over 100 detailed, printable instructions and photos for almost any bicycle maintenance task or repair
- “Tool Locator” for helping select the right tool for the job
- Dealer locator with special Park Tool School references and links
- Recommended tool lists for mechanics of various levels of expertise

@Park\_Tool



www.facebook.com/parktool



http://www.youtube.com/user/parktoolcompany

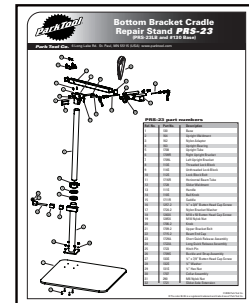

Expanded product diagrams make finding replacement parts easy



Easy to use, in depth repair help section

In this catalog you'll find 58 pages of our best work. We don't make blinking lights, tires, handle grips or car racks. We make tools and repair equipment for bicycles. We've been doing it for fifty years and we love it. Tool making is in our blood and we spend all day every day thinking of better, faster, more efficient ways to repair and maintain bicycles.

As we head into our next fifty years we want you to know we don't take our position as the world's largest and best known bicycle tool maker lightly. For 2014 we're adding 16 new tools to a line that already includes over 400 products and we're committed to staying ahead of an industry that's always changing. Yes, it's a challenge, but we like it that way. It's in our (blue) blood. We make tools for bicycles.

Eric Hawkins, President



**The rest of the story... John 1:12**

*12 Yet to all who received Him, to those who believed in His name, He gave the right to become children of God.*

©2013 Park Tool Company. All rights reserved. Specifications subject to change without notice. Printed in U.S.A. on recycled paper. 10% Post consumer fiber.

PARK TOOL® and the color BLUE are registered trademarks of Park Tool Co. All other referenced trademarks and trademark registrations are the property of their respective owners.

All other product names and marks in the Park Tool catalog whether trademarks, service marks, or other intellectual property, and whether registered or unregistered, are the property of their respective owners. Other products and marks are used for informational purposes only and Park Tool Co. claims no right or interest in such marks.



A. BBB-3



### A. BBB-3 Big Blue Book of Bicycle Repair – 3rd Edition

Updated with new information, techniques, photos, procedures and components, the BBB-3 3rd Edition is a complete repair manual created to provide both the novice and veteran mechanic the information needed to perform nearly any repair from trailside repairs to complete overhauls.

Written by Park Tool Director of Education, Calvin Jones, the Big Blue Book is the perfect reference guide and step-by-step repair manual for nearly any bike, including road, mountain, bmx, and single-speed. **We wrote the book on bicycle repair.**

Available in English only.

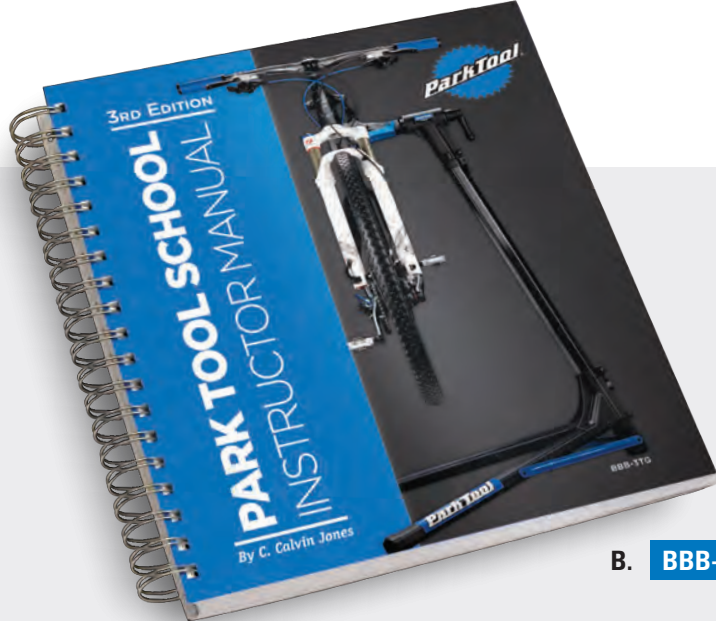

B. BBB-3TG

### B. BBB-3TG Instructor's Guide for Park Tool School

A complete tutorial and information source to help retail stores conduct their own repair and maintenance clinics based on The Big Blue Book of Bicycle Repair 3rd Edition, BBB-3. Written by Calvin Jones, Park Tool's Director of Education Programs, using his 40 years of experience as a mechanic, educator, and writer. The BBB-3TG provides all the time-proven information needed for a successful Park Tool School clinic, including:

- Detailed advice to help you plan, organize, promote and teach a clinic
- Step by Step repair procedures
- Hundreds of photos
- Course outlines, lecture notes and demonstration ideas
- Student participation certificates, a promotional poster and sample registration forms

Available in English only.

Repair clinics are a great way for bike shops to show their expertise, attract new customers, and help current customers keep their bikes running smoothly. The Park Tool School is a program and curriculum designed to make the planning and teaching of repair clinics easy. A skilled shop staff, a copy of the BBB-3TG Instructor's Guide, and a BBB-3 Big Blue Book of Bicycle Repair for each clinic participant are all it takes to get started. Bike shops offering the Park Tool School are posted on the Park Tool web site, where those interested can access a list of participating shops.

Investing in a high quality repair stand is the first step toward building a high quality workstation. Over the past 50 years we've built hundreds of thousands of repair stands for home mechanics, shop mechanics, and professional race mechanics all over the world. Many of the PRS-1 stands we built in the 1960's are still in use daily, and we're constantly striving to improve and update our newest generation of stands. Each of our models offer different features and benefits to ensure a model for nearly every purpose. All of our stands are made to allow full rotation to ensure a comfortable working position at all times. We also offer a complete line of replacement parts to keep your investment running smoothly. Ask any professional mechanic about their stand and you're bound to hear "Park Tool" as the response. Insist on the quality and innovation of genuine Park Tool repair stands. Designed and built to last for years of use.

### A. PRS-2 OS Deluxe Double Arm Repair Stand

The industry standard for over 40 years. Outstanding stability and a working height range of 50" to 62" (127-158cm) - high enough and stable enough to position the bike at a comfortable working height even when clamping on the seat post. Available with a choice of our 100-3C clamps or the new 100-3D clamps (descriptions on pages 9 and 10) which rotate 360°. Because the stand itself also rotates horizontally 360 degrees, one bicycle can be swung out of the way, allowing the other clamp to be used for "rush" repair jobs. The entire framework is heavily chrome plated for stability. Stand does not include base. Order part #135 base.

Your choice of two different configurations:

- **PRS-2 OS-1** Includes two 100-3C Adjustable Linkage Clamps
- **PRS-2 OS-2** Includes two 100-3D Micro-Adjust Clamps (pictured)
- **#135** 115 pound (52kg) steel plate base for PRS-2 OS-1 and PRS-2 OS-2

### B. PRS-3 OS Deluxe Single Arm Repair Stand

This stand is one half of the Park Tool Deluxe Double Arm Repair Stand (PRS-2 OS), and incorporates most of the same features in a stand suitable for smaller areas or single workstations. Available with a choice of our 100-3C clamp or the new 100-3D clamp (see descriptions pages 9 and 10). Height adjustable from 50" to 62" (127-158cm). Utilizes large diameter chrome plated steel tubing for stability. Stand does not include base. Order part #130 base.

Your choice of two different configurations:

- **PRS-3 OS-1** Includes 100-3C Adjustable Linkage Clamp
- **PRS-3 OS-2** Includes 100-3D Micro-Adjust Clamp (pictured)
- **#130** 65 pound (29.5kg) steel plate base for PRS-3 OS-1 and PRS-3 OS-2



100-3C Clamp



100-3D Clamp

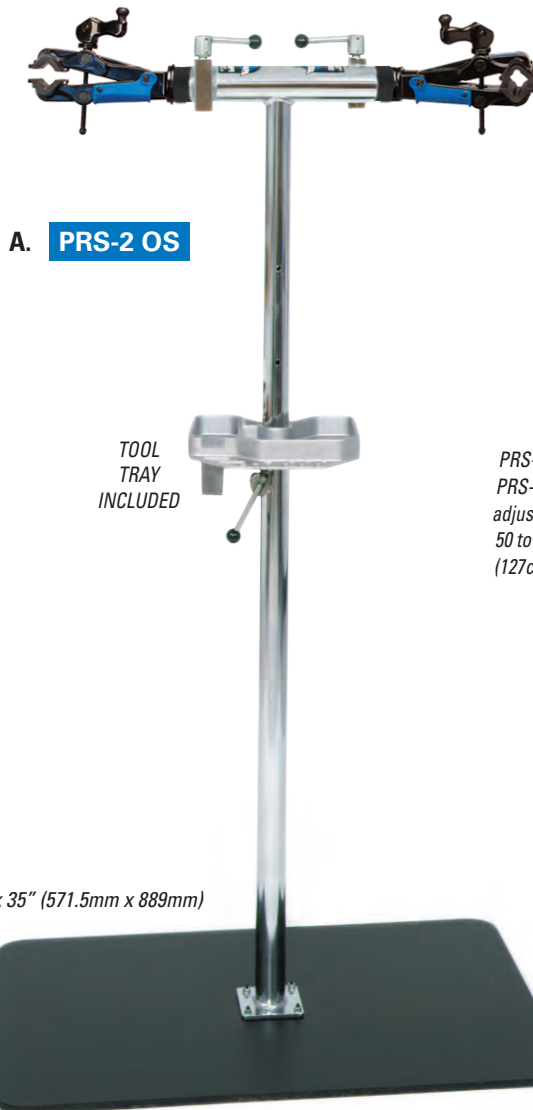

A. PRS-2 OS

TOOL TRAY INCLUDED

22.5" x 35" (571.5mm x 889mm)



B. PRS-3 OS

TOOL TRAY INCLUDED

22.5" x 22.5" (571.5mm x 571.5mm)

PRS-2 OS and PRS-3 OS both adjustable from 50 to 62 inches (127cm-158cm)

### C. PRS-33 Power Lift Shop Stand

The biggest, strongest, stiffest, most versatile repair stand ever built. We created the PRS-33 with professional mechanics in mind blending a massive upright with the ease and convenience of a powered lift. The size and strength ensures a super rigid workstation able to go higher than ever before and the power lift allows effortless height adjustment for any bike up to 120 pounds (54kg). Perfect for lifting heavy electric bikes or for mechanics with lifting limitations but also great for easy height changes during a repair or set up. The PRS-33 is a single arm stand but can be made into a double arm stand with the addition of part number PRS-33 AOK.

#### Features:

- Adjustable height from 9" to 78" (23cm-198cm)
- Integrated work tray
- Integrated accessory bar to hang wheels, air hoses, lights and just about any other accessory you can think of
- Electric motor able to smoothly lift 120 pounds (54kg)
- Oversized gussets to mount stand directly to the floor
- 100-3D Micro Adjust clamp

*100-3D Micro-Adjust Clamping system and integrated work tray*



*Top mounted, integrated accessory bar*



#### Optional Components:

- **#135-33** 115 pound (52kg) steel plate base with floor levelers
- **#450 Machine Thread Hook** Black vinyl coated. Includes two nuts.

### D. PRS-33 AOK 2nd Arm Add On Kit

Make it a double arm stand! Turns the PRS-33 single arm stand into a double arm stand. Complete with clamp, sliding carriage, work tray, electric motor, power source, chain and hardware.



#### D. PRS-33 AOK

*94" height (238 cm) with base and accessory bar  
(not using accessory bar will reduce height by 2-3/4")*

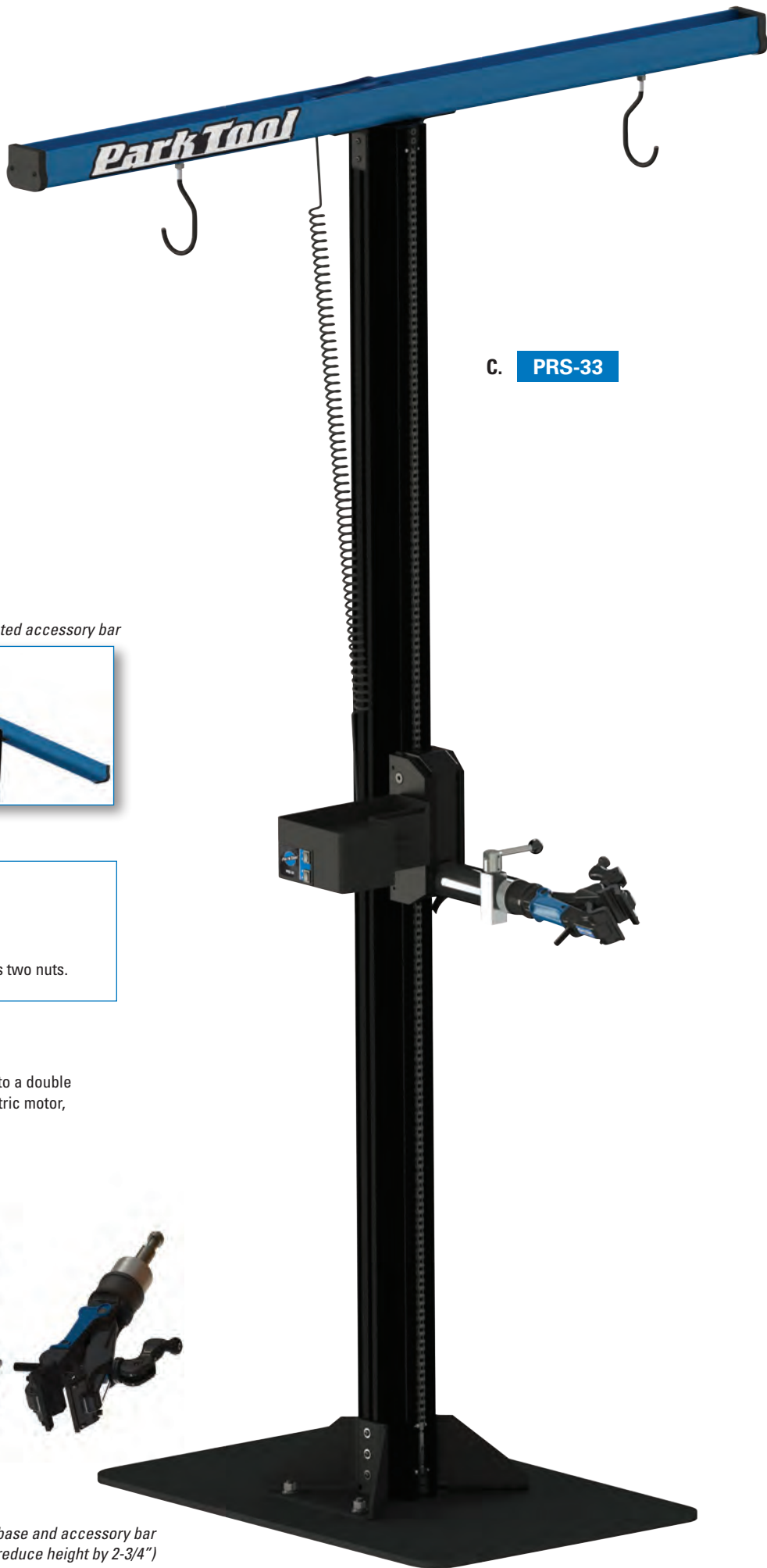

C. PRS-33

**A. PRS-25**



Clamping height quickly adjusts from 45 to 60 inches  
111.8cm to 152.4cm

**A. PRS-25 Team Issue Portable Stand**

We started from the ground up...literally...to create what we believe is the finest folding stand available. Lightweight, stable and packed with features, the PRS-25 is designed and built to perform on smooth concrete or rough terrain. Featuring our 100-25D Professional Micro-Adjust Shop Clamp, the PRS-25 folds easily into a neat little package. Built with our own proprietary Hexatude™ hex-shaped extruded aluminum tubing and utilizing our mechanic proven three-point leg system, this stand is solid yet weighs a scant 13 pounds (6 kg).

**Features:**

- Quickly and easily folds to 47" x 9" x 9" (119cm x 23cm x 23cm)
- Clamping height adjusts up to 60"(152.4cm)
- Park Tool's exclusive Hexatude™ hex shaped extruded aluminum tubing ensures low flex and no rotation
- Aluminum leg straps ensure all parts slide, fold and unfold together
- Weighs less than 13 pounds (6 kg)
- 360° infinite position clamp rotation
- 100-25D Professional Micro-Adjust Shop Clamp (see description on page 9)



PRS-25 folded and clamp securely stowed

**ACCESSORIES**

**E. TS-25 Repair Stand Mounted Wheel Truing Stand**



Small, lightweight, portable and accurate, the TS-25 securely holds any wheel using a quick release or threaded axle and adjusts for any wheel diameter and rim width. Installs and removes quickly and easily. Fits PRS-25, PCS-1, PCS-4 and PCS-10 Repair Stands.

**E. TS-25**



**F. TS-TA**

**F. TS-TA Thru Axle Adaptor**

The TS-TA makes it possible to adapt all Park Tool Truing Stands to work with 12mm, 15mm and 20mm thru axle wheels, as well as Cannondale® Lefty™ wheels. For use with TS-25.

**G. BAG-15**



**G. BAG-15 Travel & Storage Bag**

Heavyweight nylon bag with shoulder strap for transporting and storing the PCS-9, PCS-10, PCS-11, PRS-15 and PRS-25.

**H. PTH-1 Paper Towel Holder**

Paper towels are always handy for cleaning hands and parts. Keep them within reach with the PTH-1. Fits into the Receiver Ports of any PRS-25, PRS-15, PCS-11 and PCS-10 to hold a standard roll of paper towels. Also works great for hanging clothing, wheels, tires, etc.



**H. PTH-1**

**Accessory Use Guide:**

Product Name	For use with:
<b>TS-25</b> Repair Stand Mounted Wheel Truing Stand	PRS-25, PCS-1, PCS-4 and PCS-10
<b>TS-TA</b> Thru Axle Adapter	TS-25, TS-8, TS-2, TS-2.2
<b>106-AC</b> Accessory Collar	PCS-9 Post 2003: PCS-1, PCS-4
<b>106</b> Tray	PRS-15, PRS-25, PCS-10, PCS-9 Post 2011: PRS-20, PRS-21 Post 2003: PCS-1
<b>PTH-1</b> Paper Towel Holder	PCS-10, PCS-11, PRS-15 and PRS-25
<b>BAG-15</b> Travel & Storage Bag	PCS-9, PCS-10, PCS-11, PRS-15 and PRS-25

## PCS-9 and PCS-10 Folding Repair Stands

Each of these folding stands is designed to fold small, adjust in height and clamp a huge variety of tubing and tubing sizes. The unique three-point leg system creates an extremely solid base capable of handling nearly any bike.

- Height adjusts from 39" to 57" (99cm to 145cm)
- Clamps adjust to fit tubes from 7/8" to 3" (24mm to 76mm) and utilize a narrow 3 1/2" (89mm) clamping surface to fit into tight places
- Replaceable jaw covers (#1185K)
- Clamp rotates 360 degrees for easy access to any part of the bike
- Adjustable clamp pressure prevents damage to thin wall tubes
- Folds to 41" (104cm) in length for portability and storage
- Durable, wrinkle finish powder coat



**B. PCS-10**

### B. PCS-10 Home Mechanic Repair Stand

Built with a few upgrades from the PCS-9 to make set up, take down and use, quicker and easier.

- Quick adjust, cam-type clamp allows single action clamping
- Quick release height adjustment
- Quick release and locking sliding yoke for fast folding and extra stability
- World famous composite top tube for smooth rotation and solid locking
- Spring buttons lock folding legs in place
- Exclusive receiver pod accessory system integrated into the top tube and height adjustment collar to allow easy installation of PTH-1 Paper Towel Holder



**C. PCS-9**

### C. PCS-9 Home Mechanic Repair Stand

Park Tool quality in an entry-level stand.



PCS-9 & 10 Folded



**D. PCS-4**

### D. PCS-4 Deluxe Home Mechanic Repair Stand

The PCS-4 is a heavy duty folding stand with your choice of shop quality clamps. Choose either the 100-5C Adjustable Linkage Clamp or the 100-5D Micro-Adjust Shop Clamp (see descriptions pages 9 and 10). Perfect for heavier duty home use or portable shop use, the PCS-4 features a rock solid, four-point leg system that folds together for storage, steel powder coated tubing, and a composite horizontal tube. Clamp rotates 360° and is adjustable in height up to 67" (170cm).

Your choice of two different configurations:

**PCS-4-1** Includes 100-5C Adjustable Linkage Clamp

**PCS-4-2** Includes 100-5D Micro-Adjust Clamp (pictured)

## I. 106 Tray

A great work stand accessory built to keep tools, lubes and spare parts right at your fingertips. The #106 installs easily utilizing our exclusive receiver pod accessory system found on the PRS-15, PRS-25, PCS-10, PCS-11, post 2011 PRS-20 and PRS-21, as well as PCS-9 and post 2003 PCS-1 and PCS-4 when used with part #106-AC Accessory Collar (available separately). Perfect for the races, ride support or as a convenient way to keep tools and supplies handy.

### Features:

- Universal, large compartment
- Small compartment
- Lube holder
- Integrated tab system holds plastic market bag for trash
- Universal tool/towel bar
- Two receiver pods to accept accessories
- Easy on and off



**I. 106**

## J. 106-AC



### J. 106-AC Accessory Collar

Easily adapts the #106 Tool Tray or PTH-1 Paper Towel Holder to fit PCS-9 and post 2003 PCS-1 and PCS-4 Repair Stands.

## A. PRS-20 Team Race Stand

The PRS-20 Team Race Stand is a compact, Euro-style work stand that securely holds the bike without clamping the frame tubes or seat post. Ideal for bikes with ultra lightweight frame tubes and seatposts, and for bikes with tight access areas that can't be clamped. Originally designed for the mechanics of the Tour de France-winning US Postal Service Pro Cycling Team, the PRS-20 is now available to professional and home mechanics everywhere.

- Quick release mounts hold bike securely by the front or rear dropouts
- Taller vinyl-covered cradle to create extra clearance between bottom bracket and stand
- 360 degree horizontal rotation allows easy access to both sides of bike
- Folds to 33" (84cm) for easy transport and storage
- Stable tripod base
- Bottom bracket height quickly adjusts from 28" to 38" (71cm to 96cm)
- Durable blue powder coat finish. High wear parts are chrome plated
- Extra long, quick release retention strap to stabilize bottom bracket
- Accepts #106 Work Tray



PRS-20 Mounted to rear dropouts



PRS-20 Folded

A. PRS-20



B. PRS-21

## B. PRS-21 Super Lite Team Race Stand

Same great stability, versatility and features as the PRS-20, yet weighs only 13.5 lbs (6.2 kg), 35% less than the PRS-20. Built using the perfect combination of steel for strength in joints and pivots, and aluminum to save weight. The PRS-21 is the perfect stand to choose when size and weight are important. Ideal for the traveling mechanic or any mechanic who has to have the best and lightest. Accepts #106 Work Tray.



# PRS-20 AND PRS-21 ACCESSORIES



**C. BAG-20**

## C. BAG-20 Storage and Travel Bag

Heavyweight nylon bag with shoulder strap for transporting and storing the PRS-20 and PRS-21.



**D. 1707.2**

## D. 1707.2 Collar (Tool Tray Ready)

Replacement collar for Pre-2012 PRS-20 and PRS-21 stands to accept installation of #106 Work Tray.



**E. 1728-TA**

## E. 1728-TA Sliding Thru Axle Adaptor

Converts any PRS-20, PRS-21 or PRS-23 to accept 15mm and 20mm thru axle wheeled bikes.

## F. PRS-4W Deluxe Wall Mount Repair Stand

Designed to be easily mounted to any post or wall stud, the PRS-4W is a shop quality stand offered with your choice of two different clamps, the 100-3C or 100-3D (see descriptions pages 9 and 10). Main tube is powder coated for long life. (Mounting bolts not included)

Your choice of two different configurations:

**PRS-4W-1** Includes 100-3C Adjustable Linkage Clamp

**PRS-4W-2** Includes 100-3D Micro-Adjust Clamp (pictured)



**F. PRS-4W**

## G. PRS-4 OS Deluxe Bench Mount Repair Stand

The Deluxe Bench Mount Stand is offered with your choice of two different shop clamps, the 100-3C or 100-3D (see descriptions pages 9 and 10). The clamp rotates 360 degrees, allowing the bike to be positioned at any angle. Mounts easily to any flat surface. (Mounting bolts not included)

Your choice of two different configurations:

**PRS-4 OS-1** Includes 100-3C Adjustable Linkage Clamp

**PRS-4 OS-2** Includes 100-3D Micro-Adjust Clamp (pictured)



**G. PRS-4 OS**

## H. PRS-7 Bench Mount

Easily mounted on any workbench and offered with your choice of two different shop clamps, the 100-5C and 100-5D (see descriptions pages 9 and 10). Durable powder coated upright and composite horizontal tube. (Mounting bolts not included)

Your choice of two different configurations:

**PRS-7-1** Includes 100-5C Adjustable Linkage Clamp (pictured)

**PRS-7-2** Includes 100-5D Micro-Adjust Clamp



**H. PRS-7**

## I. PCS-12 Home Mechanic Bench Mount Repair Stand

A bench mount version of our popular PCS-10 Home Mechanic Repair Stand. Features a quick adjusting cam-type clamp that fits tubes up to 76mm (3") and rotates 360 degrees for easy access to any part of the bike. Clamping pressure is fully adjustable to prevent damage to thin walled tubes. Durable powder coat finish. Mounts to any flat surface. (Mounting bolts not included)



**I. PCS-12**

## A. 100-3D / 100-5D / 100-25D Professional Micro-Adjust Clamp

After years of research and testing we've built what we consider the best shop clamp ever made. It's smooth, versatile and built to stand up to constant, everyday shop use. With its rapid release, micro-adjust clamping system, the narrow jaws can be easily and quickly adjusted to clamp nearly any tube, at any pressure. Release the cam handle, the pressure is released and the jaws open wide enough to remove the bike.

Three configurations available:

**100-3D** Fits PRS-2, 3, 4 and PRS-2 OS, 3 OS, 4 OS, and PRS-4W

**100-5D** Fits 2001 and later PCS-1, PCS-4, and PRS-7 with composite top tubes

**100-25D** Fits PRS-25, PCS-10, PCS-11, and PCS-12



A. **100-3D**  
**100-5D**  
**100-25D**



- **Built to last:** Powder coated, precision machined, die-cast aluminum main body parts and high quality small parts.
- **Infinitely adjustable:** Micro adjustability for perfect clamping pressure every time, every tube.
- **Fast operation:** Cam actuated adjustment system for quick entry, adjustment and exit. Handy "spinner" handle helps speed large size range adjustments.
- **Gentle, firm grip:** Soft yet durable composite rubber clamping pads and a unique Soft Touch saddle cradle provide a perfect spot to temporarily rest a bike by its saddle.
- **Versatile:** Grips nearly any tube including aero shaped tubing and seat posts 7/8" to 3" (23mm-76mm). Its narrow clamping jaws (2.7"/70mm) are designed to clamp securely yet fit into tight areas or on short seat posts.

## B. 100-7X Extreme Range Clamp

Featuring a fast and secure quick release pivot system and a durable size adjustment system built for years of daily use. Our most versatile clamp, the 100-7X fits all PRS-2, 3 and 4 (including OS models) repair stands and works on nearly any bike no matter the size and shape of the frame tube.

- Clamps oversized, square, rectangular, and even aero shaped tubes
- Quickly adjusts from 7/8" to 4"
- Pivots 90 degrees to clamp either top and bottom or left and right sides of tube
- Adjustable clamping pressure prevents damage to thin-wall tubes
- Narrow jaws for clamping in tight access
- Fits any PRS-2, PRS-2 OS, PRS-3, PRS-3 OS, PRS-4, PRS-4 OS or PRS-4W repair stands

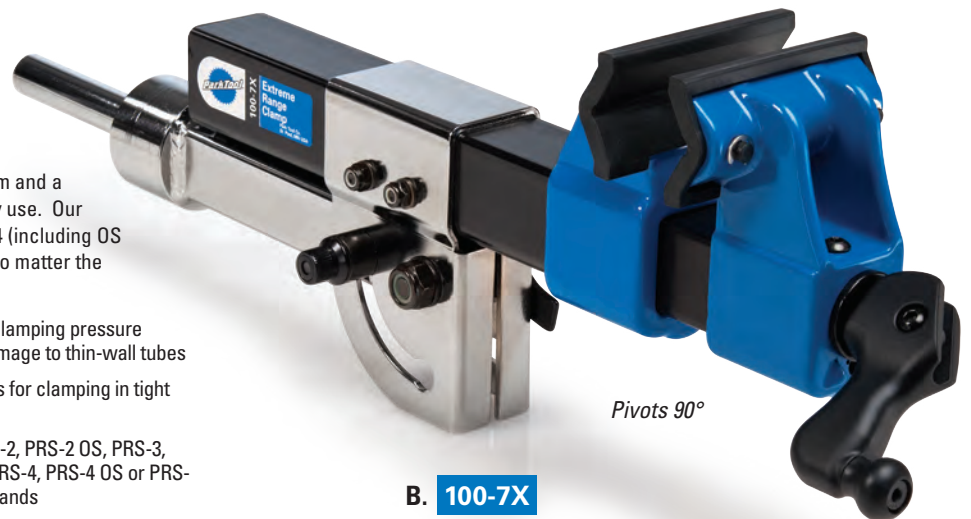

B. **100-7X**

## Replacement clamps fit frame tubes from 1" to 1-5/8" (25 to 41mm), allow for cable routing on the top tube, and feature replaceable jaw covers.

**C. 100-1C** Spring Linkage Clamp  
Fits PCS-1 and PCS-2 stands made after 6/96.



**D. 100-5C** Adjustable Linkage Clamp  
Fits PCS-4, PRS-5, PRS-6, and PRS-7 stands made after 6/96.

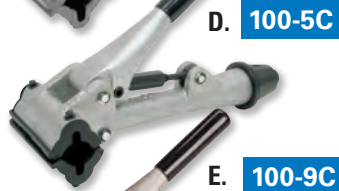

**E. 100-9C** Adjustable Linkage Clamp  
Fits PRS-6, PRS-7, and PRS-8 made before 6/96.



**F. 100-3C** Adjustable Linkage Shop Clamp  
Found in more shops than any other professional level clamp the 100-3C easily adjusts to clamp tubes from 1" to 1-5/8". Solid cast aluminum construction and featuring supple, yet durable replaceable clamp covers. Fits PRS-2, PRS-2 OS, PRS-3, PRS-3 OS, PRS-4, PRS-4 OS, and PRS-4W.

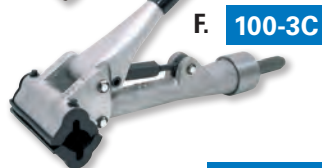

**G. 100-15X** Extreme Range Clamp  
Replacement clamp for PRS-15 repair stand.



### H. PRS-CRK Repair Kit for 100-3C Clamp

The most common replacement parts for our shop clamp 100-3C.

Includes a complete adjusting linkage #122S (#122S includes #118S, #117S-1, #121S and #136), 2-#116S cap screws, #108S-2 pin and clips, and 2-#107S-2 pins and clips.

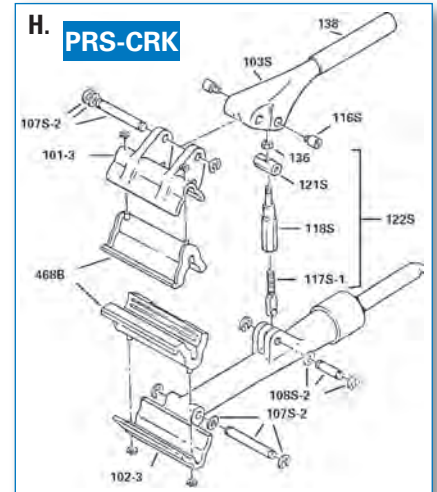

### Replacement Clamp Covers

Available in nine models to fit all Park Tool Repair Stand clamps.

- **468G:** Fits PCS-1 and PCS-2 with double cable reliefs
- **468B:** Fits PRS-2 through PRS-8 and PCS-4 with double cable reliefs
- **467B:** Fits PRS-2 through PRS-8 with single cable relief
- **467G:** Fits PCS-1 and PCS-2 with single cable relief
- **466:** Fits original clamps with plastic-dipped jaws. Old plastic should be removed before installing new covers
- **1002:** Fits 100-3X and 100-5X clamps
- **1259:** Fits PRS-15, 100-4X, 100-6X, 100-7X and 100-15X clamps
- **1185K:** Fits PCS-9, PCS-10, PCS-11, and PCS-12 clamps
- **1960:** Fits 100-3D, 100-5D, and 100-25D clamps

## ACCESSORIES



### I. 105 Cast Aluminum Tool Tray\*

The 105 is a handy and sturdy cast aluminum tray with deep-walled compartments and assorted slots for holding tools, lubes, and small parts. Fits all PRS-2, PRS-2 OS, PRS-3, PRS-3 OS, and PRS-13 Shop Stands, as well as PRS-6, PCS-1, and PCS-4 Repair Stands manufactured after 6/96.



### J. 104 Work Tray\*

This large tray is ideal for holding small parts and tools. It features deep sides so small items stay put. A variety of slots and holes hold any tool. Fits PCS-1, PCS-4, PRS-2, PRS-3, PRS-6, PRS-11 & PRS-12.



### K. FP-2 Floor Plate

Permanently and securely attach your Park Tool Repair Stand to the floor of your shop with our Floor Mounting Plate. Made with an 8" square of steel, it attaches to stand with four bolts, which are included.



### L. HBH-2 Handlebar Holder

The Handlebar Holder is designed to prevent the handlebar and front wheel from rotating when a bike is mounted in a Park Tool Repair Stand. Updated to fit handlebars with a diameter up to 32mm and oversized top tubes up to 50mm, the HBH-2 works on almost any road or mountain bike.



### M. ISC-4

### M. ISC-4 Internal Seat Tube Clamp

Clamping directly to freshly painted or ultra thin-walled frame tubing can cause inadvertent damage. The ISC-4 securely holds most bikes without clamping on any frame tube. To use, simply insert the ISC-4 into the frame's seat tube, tighten the knob, and clamp into any Park Tool Repair Stand. The ISC-4's hex-shaped shaft resists twisting while clamped in the stand. Works with a huge range of seat tube sizes—anything with an inside diameter of 24mm to 32mm.



**A. TS-8**

### A. TS-8 Home Mechanic Wheel Truing Stand

Designed especially for the home mechanic, the TS-8 allows accurate wheel truing at an economical price. Accepts wheels from 16" to 29", with or without the tire mounted. Innovative sliding dropout allows quick wheel installation, no matter what the hub width (up to 170mm). Dishing (centering) is performed by simply flipping the wheel in the stand. Constructed from heavy gauge steel to resist flexing, the TS-8 can be used freestanding or bolted to a bench for extra stability.

## TS-2 AND TS-2.2 ACCESSORIES



### B. TS-TA Thru Axle Adaptor

The TS-TA makes it possible to adapt all Park Tool Truing Stands to work with 12mm, 15mm, 20mm and 25mm thru axle wheels, as well as Cannondale® Lefty™ wheels.

**B. TS-TA**



**C. TS-2TA**

### C. TS-2TA Thru Axle Adaptors

These simple dome shaped adaptors clamp into the "V" shaped axle holders on either the TS-2 or TS-2.2, allowing the stand to be used with wheels using 15mm and 20mm thru axle hubs.



**D. TS-2EXT.2**

### D. TS-2EXT.2 Upright Extensions and Thru Axle Adaptors for TS-2

Truing Stand Upright Extensions install in seconds on any TS-2 Truing Stand, allowing the stand to be used on wheels with hubs up to 200mm wide (tandem, fat and downhill bikes), as well as on wheels with a 29" mountain bike tire installed. In addition, specially sized bosses on the TS-2EXT.2 serve as adaptors so the TS-2 Truing Stand can be used with wheels using 12mm, 15mm, 20mm or 25mm thru-axle hubs with removable axles.

**Note:** TS-2.2 does not require this adaptor to accommodate 29" wheels but does require it to fit hub widths from 180mm to 200mm.



**E. TSB-2**

### E. TSB-2 Truing Stand Tilting Base

Fits any TS-2 or TS-2.2 and tilts 20° forward or back for comfortable wheel work at any bench height. The TSB-2 has a wide, sturdy base and features small parts bins and spoke wrench holders.

### F. 238K Caliper Upgrade Kit

Upgrade your TS-2 to accept larger wheels and wider tires. Set includes a set of left and right calipers along with removable/replaceable composite tips.

### G. 1554-1 Centering Gauge for TS-2, TS-2.2 and TS-3

## H. TS-2.2 Professional Wheel Truing Stand

The world's best-known wheel truing stand and the standard of the industry is now, more than ever, the stand to choose for shop use. The TS-2.2 is smoother, more accurate, more versatile and easier to use than any other stand, anywhere. The TS-2.2 combines time-tested functions from the TS-2 with new technology and features sure to make your job easier.

### Features:

- Both axle holding uprights move simultaneously to accommodate front and rear wheels with the turn of a knob
- Nickel chrome plated, heavy gauge steel. Built to last for decades
- Easily adjusts to maintain accuracy
- Spring loaded calipers and caliper arm to prevent binding
- Can be bench mounted or installed in a bench vise
- Easily adjusts to accommodate multiple wheel sizes and widths up to 175mm
- Smooth, accurate operation
- Longer uprights to accommodate wheels up to 29" with or without a tire
- Stronger, stiffer uprights to reduce flex and improve accuracy and repeatability
- Stronger, more ergonomic knobs
- Removable, replaceable nylon caliper tips to protect painted rims
- Taller, more accurate calipers to accommodate tire widths up to 4"

## I. TS-2Di



### I. TS-2Di Dial Indicator Gauge Set

Measures wheels lateral and radial run-out at the same time. The TS-2Di easily mounts to any TS-2 or TS-2.2 and provides measurable accuracy for your truing stand and for your customers. Each dial's measurement reads to .01mm and enables the user to set and follow tolerances for each wheel. Each set comes complete with brackets, dials and specially designed tips.



## H. TS-2.2

## A. TM-1 Spoke Tension Meter

The key to wheels that are strong and reliable is having spokes that are properly and uniformly tensioned. The TM-1 Tension Meter accurately and reliably measures the absolute tension of each of the spokes in a wheel, as well as the relative tension between all the spokes in a wheel. Easy to use and priced affordably, the TM-1 works on nearly any bicycle spoke—no matter what the diameter, material, or shape. Not just for the experienced mechanic, the TM-1 is for anyone building or truing wheels, diagnosing wheel problems, or assembling new bikes. It's a tool that belongs on every workbench. Includes an indispensable laminated tension chart to convert tool readings to actual measured tension for nearly any spoke.



A. TM-1



B. BSH-4

## B. BSH-4 Bladed Spoke Holder

The BSH-4 is a valuable wheel building and truing aid that securely holds bladed spokes in place to prevent twisting. Four different sized slots to fit a wide variety of bladed spokes.

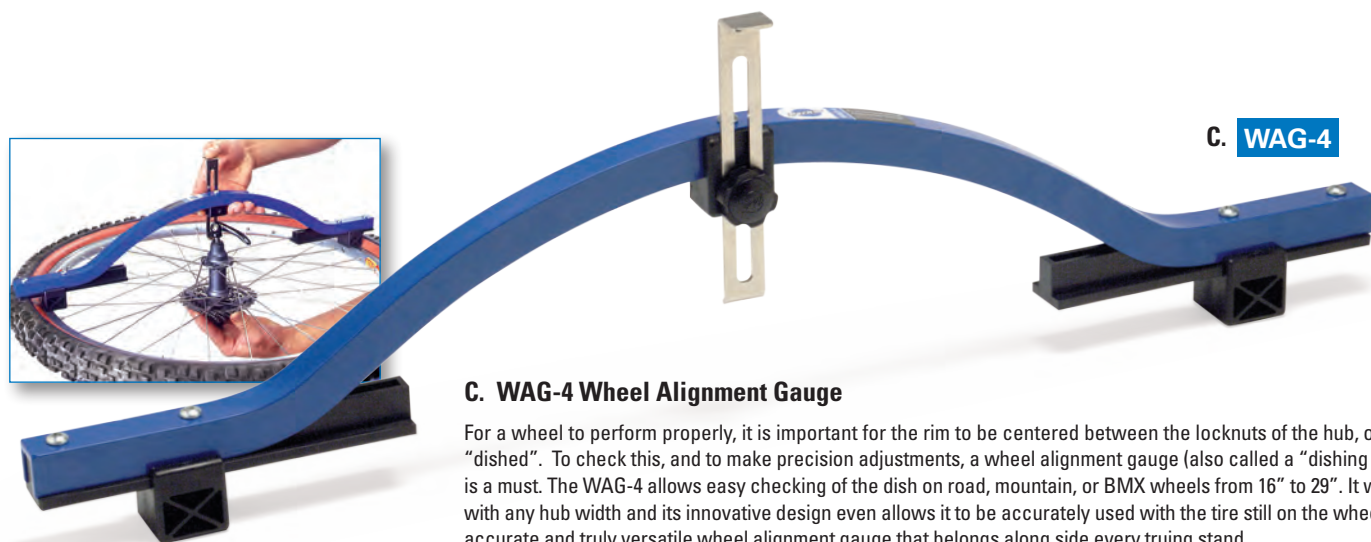

C. WAG-4

## C. WAG-4 Wheel Alignment Gauge

For a wheel to perform properly, it is important for the rim to be centered between the locknuts of the hub, or "dished". To check this, and to make precision adjustments, a wheel alignment gauge (also called a "dishing tool") is a must. The WAG-4 allows easy checking of the dish on road, mountain, or BMX wheels from 16" to 29". It works with any hub width and its innovative design even allows it to be accurately used with the tire still on the wheel. An accurate and truly versatile wheel alignment gauge that belongs along side every truing stand.



D. WAG-5

## D. WAG-5 Portable Wheel Dishing Gauge

Accurately gauges dish (centering) of 26" to 29" wheels. Disassembles quickly for storage or travel and works with all hub types.



E. SBC-1

## E. SBC-1 Spoke, Bearing, & Cotter Gauge

This handy shop aid is ideal for sizing spokes, ball bearings and crank cotters. To use, just hang the head of the spoke in the oblong hole and read its length on the scale. For crank cotters and ball bearings it works just like a gauge for drill bits. Spoke lengths are in both metric and fractional markings. Made of anodized aluminum with embossed markings to allow easy reading and long life.

## F. SW-0 through SW-5 Spoke Wrench

Professional quality, precision-sized spoke wrenches are hardened and nickel plated for long service. Park Tool Spoke Wrenches are vinyl coated in one of five colors indicating the size at a glance.

- **SW-0 (Black):** 80 ga. / .127" nipple / 3.23mm
- **SW-1 (Green):** 80 ga. / .130" nipple / 3.30mm
- **SW-2 (Red):** 80 ga. / .136" nipple / 3.45mm
- **SW-3 (Blue):** 105 ga. / .156" nipple / 3.96mm
- **SW-5 (Grey):** DT Torx® Style Splined Nipple

SW-0 through SW-5



### BEWARE OF POOR FITTING IMITATIONS!

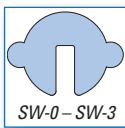

Spoke wrench bottom view

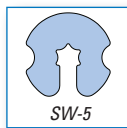

SW-5

## G. SW-40 / SW-42 Four-Sided Spoke Wrench

Unique four-sided design provides extra strength and support and helps prevent slipping and deformation of aluminum nipples. A different approach using the same world famous design and high quality materials as our three-sided spoke wrenches.

- **SW-40 (Black):** 80 ga. / .127" nipple / 3.23mm
- **SW-42 (Red):** 80 ga. / .136" nipple / 3.45mm

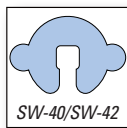

SW-40/SW-42

Spoke wrench bottom view

SW-40 • SW-42



SW-12



## H. SW-12 Spoke Wrench for Mavic® Wheel Systems

Comfortable, vinyl dipped, double-ended spoke wrench for select Mavic® wheels. Smaller end fits 7-spline nipples with a 6.4mm outside diameter. Larger end fits 6-spline 9mm diameter FORE drilled rim adapters.

SW-13



## I. SW-13 Spoke Wrench for Mavic® Wheel Systems

Similar construction to the SW-12. Smaller end fits 6-spline nipples with a 5.5mm outside diameter. Larger end fits 6-spline 9mm diameter FORE drilled rim adapters.

SW-14



## J. SW-14 Spoke Wrench for Shimano® Wheel Systems

Two-sided and vinyl dipped, featuring 4.3mm and 4.4mm openings to fit Shimano® wheel system nipples.

SW-14.5



## K. SW-14.5 Spoke Wrench for Shimano® Wheel Systems

Fits Shimano® 4.3 and 3.75mm spoke nipples.

SW-15



## L. SW-15 3-Way Internal Nipple Wrench

Our innovative 3-way "Y" wrench featuring three different sized wrenches to fit internal spoke nipples. Featuring a square drive, plus 5mm and 5.5mm hexes that slip perfectly into the tight surroundings of most rims. The SW-15 works on wheels made by numerous manufacturers including, but not limited to: FSA®, Blackwell®, Planet-X®, HED®, Rolf®, Bontrager®, Campagnolo® and Mavic®. **Note:** Wheel manufacturer's specifications change without notice.

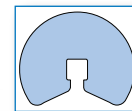

Spoke wrench bottom view

M. SW-20 • SW-22

## M. SW-20 / SW-22 Master Spoke Wrench

Destined to become a classic! The spoke wrench is an investment cast workhorse poured from the best steel, precisely machined, heat treated for hardness then polished and plated. The result is a smooth, solid steel spoke wrench designed and built to fit perfectly in your hand and provide years of every day service. A classic, and maybe your new favorite tool!

- **SW-20 (Black):** .127" • **SW-22 (Red):** .136"

## N. SW-7 Triple Spoke Wrench

The precision sized SW-7 fits the three most popular spoke nipple sizes on the market. Sizes equal to SW-0, 1, 2.

The SW-7 is nickel plated for years of service. Designed for the home mechanic.

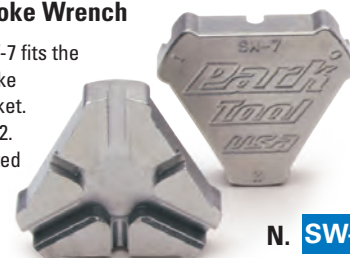

N. SW-7

O. SW-10



## O. SW-10 Adjustable Spoke Wrench

The SW-10 Adjustable Spoke Wrench helps remove tight (stubborn) or rounded nipples. Hardened, nickel plated investment casting gives superior strength and durability. Fits any of the 80 gauge sizes listed for SW-0 through SW-2.



P. ND-1 Nipple Driver

P. ND-1

A great time saver! Neatly designed to self-center and drive conventional nipples quickly and easily during wheel building. Built with a comfortable, dual density grip and lined with precision bronze bearings to ensure a long, smooth running life. The ND-1 works with rims up to 50mm deep.



Q. Internal Nipple Spoke Wrench

Q. SW-16 • SW-16.3  
SW-17 • SW-18 • SW-19

Extra long (3.25"/8.5cm) spoke wrench sockets to fit internal spoke nipples found on many deep section aero rims. Featuring our dual density, ergonomically designed screwdriver handle and available in five sizes:

- **SW-16:** 3.2mm square socket
- **SW-17:** 5.0mm hex socket
- **SW-18:** 5.5mm hex socket
- **SW-19:** 6.0mm hex socket
- **SW-16.3:** 3/16" hex socket



A. TL-1

### A. TL-1 Tire Lever Set

Sold in sets of three, Park Tool Tire Levers are made of nylon to ensure long life and damage-free operation. The unique design of the TL-1 actually lifts the tire away from the rim and keeps the tube from being pinched. These blue levers are available carded or in a 25-set counter display.

- **TL-1C:** Packaged carded
- **TL-1:** Display box (25 qty)



B. TL-4

### B. TL-4 Tire Lever Set

Wide and flat, compact and lightweight, the perfect take-along lever. The TL-4 is just the right size to stash in a bag or jersey pocket yet strong enough to remove some of the toughest tires, including most tubeless tires. Sold in pairs carded or in a retail countertop display box.

- **TL-4C:** Packaged carded
- **TL-4:** Display box (25 qty)



C. TL-5

### C. TL-5 Heavy Duty Steel Tire Lever Set

The TL-5 Heavy Duty Tire Lever Set is designed for use on the toughest tire and rim combinations. Made of forged steel, these beefy levers are a full 8" (20.3 cm) long for superior leverage. Specially designed tip engages tire bead so it can be removed with just two levers. Ideal for difficult to remove downhill and freestyle tires. Set of two.



D. TL-6

### D. TL-6 Steel Core Tire Levers

The TL-6 is a composite covered, steel core lever that provides smooth, scratch-free operation and superior strength to help remove even the tightest tires. Slightly longer (5.5"/14cm) than our other take-along levers. The TL-6 is perfect for use as a take-along or as an everyday bench lever. Set of two.



E. PTS-1

### E. PTS-1 Tire Seater

This tool is designed to quickly and easily "seat" stubborn tires. During inflation, tire beads often slip below the rim edge and are difficult to pull out. Simply place the non-slip jaws on the tire and lift out. The Park Tool Tire Seater adjusts to various tire widths. It's chrome plated and the handles are vinyl coated for comfort.



## F. TR-1 Tire & Tube Repair Kit

Our popular GP-2 Super Patch Kit and TL-1 Tire Levers packaged together as a kit. Three Tire Levers and a box with six patches and one piece of sandpaper on a blister card.



F. TR-1



## G. VP-1 Vulcanizing Patch Kit

The VP-1 Patch Kit includes six thin and flexible patches with tapered edges to blend with the tube's profile. Two each round patches 20mm & 25mm in diameter for smaller holes. Two oval patches, 25mm x 35mm, are for wider cuts. A tube of self-vulcanizing fluid bonds the patch to the tube at the molecular level. Each kit is packaged in a small plastic box with sandpaper for cleaning the tube and instructions. Available individually carded or in a handy 36 kit countertop display.

- **VP-1C:** Packaged carded
- **VP-1:** Display box (36 qty)



G. VP-1



## H. GP-2 Pre-Glued Super Patch Kit

One of our most successful products ever! We worked with 3M® to produce a self-adhesive tube patch that stretches, flexes, twists, and turns right along with the tube. No messy glue, no bulky packaging. Lightly roughen tube with the included sandpaper, clean, apply patch, and you're ready to go. Six patches with sandpaper in a neat little carry along box. Available individually carded or in a handy 48 kit countertop display.

- **GP-2C:** Packaged carded
- **GP-2:** Display box (48 qty)

H. GP-2



## I. TB-2 Emergency Tire Boot

The fastest, easiest, and most secure way to repair a cut or worn tire sidewall. The TB-2 is produced using a strong, waterproof vinyl membrane with fiber weave reinforcement to keep the inner tube in place. A super strong pressure sensitive adhesive assures the 76mm x 44mm boot stays in place in any tire, road or mountain, high or low pressure. A true ride saver.

I. TB-2



A. PFP-8



### A. PFP-8 Home Mechanic Floor Pump

Economical, durable and versatile, the PFP-8 is equally at home in the garage, workshop or at the trailhead.

- Composite head with thumb lock fits Presta, Schrader, and Dunlop valves without switching internal parts
- Smooth operating steel barrel
- Super stable steel base with extra large foot pads and giant, easy-to-read gauge
- Comfortable, composite handle



B. PFP-7



### B. PFP-7 Professional Mechanic Floor Pump

The PFP-7 is a heavy duty floor pump, packed with features and built for years of dependable service.

- Exclusive, easy-lock pump head clamps quickly and securely then releases with one finger.
- Fits Presta, Schrader, and Dunlop valves
- Giant, integrated, easy-to-read pressure gauge
- Large steel base with folding foot pads that lock down into position during use and lock up for easy storage and transport
- Oversized handle with "soft touch" rubber grips and an alloy core
- Extra long high pressure hose

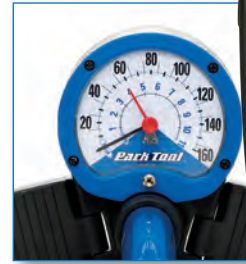

C. PFP-5



### C. PFP-5 Home Mechanic Floor Pump

The PFP-5 is a high performance, feature packed floor pump at a great price. Perfect for the home mechanic.

- Smooth operating steel barrel
- Exclusive, easy lock pump head clamps quickly and securely then releases with one finger
- Fits Presta, Schrader, and Dunlop valves without switching internal parts
- Giant, oversized, easy to read pressure gauge integrated directly into the base
- Large foot pads create a stable base in use and fold for easy storage and transport
- Long, reinforced high pressure rubber hose
- Includes ball inflating needle

## D. INF-1 Shop Inflator

Specially built for bicycles the INF-1 utilizes a dual Presta and Schrader head that rotates making valve access quick and easy. The INF-1 features an ergonomic dual density grip, built in pressure gauge (0-160 psi, 0-11 bars), and accepts any 1/4" npt male threaded fitting. Built for everyday shop use and rebuildable!



D. INF-1

## E. PMP-3



## E. PMP-3 Pocket Protector Micro Pump

This super small micro pump fits in just about any bag, jersey pocket or mounts directly to the frame. Ideal to take along when space and weight are an issue. It's small but it works like a champ with either Presta or Schrader valves. Aluminum barrel with a locking dual head and soft touch, dual density, flip out handle. (Max. pressure: 100 psi / 7 bars)

## F. PMP-4 Half-Pint Mini Pump

Just small enough to carry or clip on to the bike and just big enough to pump efficiently, the PMP-4 dual head mini pump is built like all our tools - solid! All aluminum barrel construction ensures long life and smooth operation. Soft touch grips and a flip-out handle make it easy on the hands. The PMP-4 is Presta and Schrader valve compatible and includes mounting hardware. (Max. pressure: 90 psi / 6 bars)



F. PMP-4

## G. PMP-5



Expands from 17" (43cm) = 47cm frame to 22" (56cm) = 62cm frame

## G. PMP-5 Dial Adjust Frame Pump

One size does fit all. A full-length frame pump that securely locks into nearly any frame. The PMP-5 quickly adjusts (no tools needed) to fit small to large size frames so riders can use one pump for multiple bikes and retailers can stock just one frame pump. All aluminum barrel construction ensures long life and fluid operation. The PMP-5 is Presta and Schrader valve compatible and features a dual density, soft touch flip-out handle for smooth, comfortable pumping. One pump, multiple bikes, fast and easy! (Max. pressure: 160 psi / 11 bars)

Patented

## H. VC-1 Valve Core Tool

A small, handy tool designed to remove and install Schrader and Presta valve cores and to remove and install Presta valve extenders with 5mm wrench flats.

**Note:** Not all Presta valve cores are removable.



H. VC-1



A. **HMR-4**

**A. HMR-4 Shop Hammer**

The HMR-4 has a fiberglass shaft, a soft touch rubber grip, and a two-sided head—steel on one side and a replaceable plastic head (part #293) on the other side.



B. **NP-6**

**B. NP-6 Needle Nose Pliers**

Forged, heat-treated Cro-Moly steel professional quality 6" pliers. The NP-6 features an invisible spring, soft touch dual density grips and five different crimping/grasping areas as well as cutting blade.



C. **SP-7**

**C. SP-7 Side Cutter Pliers**

Forged, heat-treated Cro-Moly steel, professional quality 7" diagonal/side cutting pliers featuring soft touch, dual density grips.



D. **UK-1**

**D. UK-1 Utility Knife**

It folds, it cuts, it hangs on your belt and best of all...it's blue. Perfect for the shop, garage, toolbox or saddlebag. The UK-1 is a combination of aluminum and stainless steel and uses readily available hardware store utility knife blades. It also features a secure, quick-change blade system that locks open and closed.



E. **SAW-1**

**E. SAW-1 Hacksaw**

All aluminum die cast frame construction, blade tension adjuster and comfortable handle make this the perfect hacksaw for the shop. SAW-1 includes one blade and accepts any 12" (300mm) hacksaw blade.



SD-2

SD-3

SD-0

SD-6

**G. SD-0 / SD-2 / SD-3 / SD-6 Screwdrivers**

Shop quality screwdrivers designed for comfort and durability. Featuring dual density grips and heat-treated, chrome vanadium tips and shafts.

- SD-0: #0 Phillips
- SD-2: #2 Phillips
- SD-3: 3mm flat blade
- SD-6: 6mm flat blade



F. **CSB-1**

**F. CSB-1 Carbon Cutting Saw Blade**

12" Tungsten steel hacksaw blade specially designed to smoothly cut carbon composite handlebars, forks, seat masts and integrated seat posts. Fits Park Tool SAW-1 and most 12" hacksaws.

**H. SD-SET Shop Screwdriver Set**

All four of our shop grade screwdrivers in one handy set.



I. MWF-1

### I. MWF-1 Metric Flare Wrench

This 8mm and 10mm wrench is used to safely open and close the compression nut on hydraulic brake calipers and levers. The MWF-1 features angled heads for easy access and unique, semi-box openings to reduce the risk of damage to the compression nut and brake line.



J. MW-SET.2

### J. MW-SET.2 Metric Wrench Set

World famous Park Tool quality wrapped up in a great set of metric combination wrenches. The MW-SET.2 includes 6mm to 17mm 12-point box/open end wrenches. Forged from chrome vanadium steel, chrome plated, meticulously polished, then center dipped in Park Tool blue vinyl for a positive grip. Strong, comfortable, and beautiful!



K. MQ-1

### K. MQ-1 Metric Quad Wrench

A handy, four-way socket wrench that provides great leverage for nut and bolt removal and installation. The MQ-1 features 15, 17 and 19mm forged sockets plus a 3/8" socket drive.



L. RP-SET

### L. RP-SET Snap Ring Pliers Set

Designed and built with the specific needs of the bike mechanic in mind. The RP-SET features three forged pliers made for internal snap rings and one for external snap rings.

Also available individually:

- RP-1: .9mm straight internal
- RP-2: 1.3mm bent internal
- RP-3: 1.3mm bent external
- RP-4: 1.7mm bent internal



M. RR-12

### M. RR-12 Tape Measure

Small and handy, the RR-12 features a tough, composite housing and both Metric and English readings up to 12 feet (3.65 M).



N. PAW-12

### N. PAW-12 12" Adjustable Wrench

Big, powerful, smooth and accurate. The PAW-12 is forged of Chrome Vanadium steel (CR-v), precision ground and machined then heat treated and nickel plated. Our adjustable wrench opens to 38mm and features a laser engraved measurement scale and a wide, comfortable handle dipped in world famous Park Tool Blue vinyl.

## A. AK-38 Advanced Mechanic Tool Kit

Designed specifically for the home mechanic who wants the best, the AK-38 Advanced Mechanic Tool Kit is a special collection of our finest “shop quality” tools, all packaged in a tough tool box. The AK-38 includes all the most frequently used tools, as well as some items a mechanic should not be without—basically, everything needed to perform most repair and maintenance tasks, from brake adjustments to headset overhauls, on the majority of current model bikes.

See page 24 for AK-38 tool list.



A. AK-38

## B. PK-65



## B. PK-65 Professional Tool Kit

Designed as a “do it all” kit for the home mechanic or as a solid starter kit for the professional shop mechanic, the PK-65 is a very special collection of our very finest shop tools. While it includes the tools needed to perform almost any basic repair or adjustment on the bike, the PK-65 also includes the specialty tools to perform many advanced repair tasks, such as installing and removing headset races, installing crown races, cutting fork steerer tubes, straightening derailleur hangers, tapping threaded frame braze-ons, dishing wheels, and more.

See page 24 for PK-65 tool list.

### C. EK-1 Professional Travel and Event Kit

A carefully chosen selection of some of our finest tools housed in the BX-2 Blue Box Tool Case. The EK-1 includes more than 35 shop level tools plus extra room for more tools and parts. Perfect for professional shop and team mechanics as well as the home mechanic who wants the ultimate portable tool kit.

See page 24 for EK-1 tool list.

### C. EK-1



### D. BX-2 Blue Box Tool Case

No off the shelf suitcase here! We started with the best professional level travel tool case we could find then customized it to work specifically with bicycle tools. Each specially designed tool pallet is housed in a super tough, dent proof tool case designed and built for daily use.

#### Features:

- Dent proof molded composite shell
- Strong, smooth anodized aluminum frame
- Removable tool boards made with tough, durable 600D ballistic nylon sewn to an ABS inner panel
- Customizable lower level with moveable partitions
- Proprietary front hanging tool board
- Lockable with both key and combination locks
- 35 tool pockets and straps plus four universal tool modules to accommodate a wide variety of tools and tool shapes

### D. BX-2



### E. BXB-2 Backpack Harness for BX-2/EK-1

Specially designed to carry the Blue Box on your back. The BXB-2 is a well-built, secure and comfortable backpack system complete with padded shoulder straps, handy accessory pouches, plus waist and chest straps. The BXB-2 is fully adjustable and set up is quick and easy.

### E. BXB-2



### F. SK-1



### F. SK-1 Home Mechanic Starter Kit

A great way to start a tool collection! The perfect combination of tools to help the novice home mechanic clean, adjust, maintain and do some basic repairs on their bike. The SK-1 includes 15 genuine Park Tool products plus a custom Park Tool toolbox.

See page 24 for SK-1 tool list.

### G. WTK-1



### G. WTK-1 Essential Tool Kit

Designed for the casual cyclist, the economical WTK-1 contains the tools needed for many basic adjustments and repairs at home or on the road. Includes: 3, 4, 5, 6mm hex wrenches; tire levers; patch kit; straight blade screwdriver, and a small adjustable wrench—all housed in a compact, ready-to-go tool wallet.

### H. BTR-1 Tool Roll

Ride saving essentials in a tight tool roll, perfect for just about any rider. The BTR-1 features the essential tools needed to fix a flat and make trail or roadside adjustments wrapped in a well-organized, protective tool roll. Just the right size to slide into most medium to large sized saddle bags and wedge packs.

#### The BTR-1 includes the following:

- Cordura tool roll with cinch strap
- GP-2 Pre-Glued Patch Kit
- TB-2 Emergency Tire Boot
- PMP-3 Pocket Protector Micro Pump
- TL-4 Tire Lever Set
- High pressure inflation gauge
- IB-1 I-Beam Fold-up Tool Set

### H. BTR-1





**MK-234** MK-234 Master Tool Kit

This is it! The tool set... to end all tool sets. Pretty much anything and everything we could think of is included in this collection. Designed for the professional, full service mechanic the MK-234 is a complete set of professional level tools, fixtures, lubricants, gauges, and accessories. The perfect way to start a repair business, open or expand a bike shop, or create the ultimate home workshop. Over 234 shop quality tools from the only company in the world capable of such a feat. Tool Envy. It's a beautiful thing! See page 24 for MK-234 tool list.





## A. MTB-3.2 Premium Rescue Tool

Now with more tools, an upgraded chain tool and a sleeker, smaller size. The MTB-3.2 is built to tackle nearly any road or trailside emergency repair. It's small enough to take along yet the protected tools feature enough leverage to make repairs quick and easy.

### Features:

- Composite protective shell doubles as two super strong tire levers
- 10-speed compatible chain tool
- Disc brake piston press
- Rotor truing tool
- 1.5, 2, 2.5, 3, 4, 5, 6 & 8mm hex wrenches
- T10, T25 & T30 Torx® compatible drivers
- Straight blade screwdriver
- Phillips head screwdriver
- 8, 9 & 10mm box wrench
- Emergency pedal wrench
- Presta valve core/extension tool (4mm)
- Bottle opener
- Three spoke wrenches (.127", .130" and .136"/SW-0, 1 and 2 sizes)
- Knife



A. MTB-3.2



B. MTB-7

## B. MTB-7 Rescue Tool

An outstanding value, the quality MTB-7 Rescue Tool is packed with 21 useful tools for emergency repairs on the road or trail. Includes nylon carrying case with embroidered Park Tool logo.

### Tools included:

- 2, 2.5, 3, 4, 5, 6, & 8mm hex wrenches
- Tire levers (2)
- Phillips head screwdriver
- Straight blade screwdriver
- T25 Torx® compatible star-shaped driver
- .127", .130", & .136" spoke wrenches
- 8, 9, & 10mm box end wrenches
- Chaining nut wrench
- Dust cap remover
- Serrated knife
- Bottle opener



C. SS-15

## C. SS-15 Single Speed Spanner

Designed and built especially for single speed bikes, the SS-15 is a forged, multi purpose ride saver. Just the right size and length (17cm/7") to take along or to wrench in the garage, the "SS" is destined to be a single speeders' favorite.

- 15mm socket - axle nuts
- 15mm open end - pedals
- Smooth, curved spoon tire lever
- Bottle opener



D. MT-1

## D. MT-1 Multi-Tool

The MT-1 is a high quality multi-tool that is uncomplicated, easy to use, and effective. Made of investment cast steel and electroless nickel plated for durability, the MT-1 features 3mm, 4mm, 5mm, 6mm, and 8mm hex wrenches; 8mm, 9mm, and 10mm socket wrenches; and a straight blade screwdriver. Each of the nine tools is carefully positioned so the MT-1 can be effectively used on those "tough to get to" nuts, bolts, and screws.

**E. IB-1**



**E. IB-1 I-Beam Mini Fold Up Hex Wrench/Screwdriver Set**

Perfect for taking on rides, the strong, compact, lightweight IB-1 features our unique I-Beam handle surrounded by 3, 4, 5, 6 and 8mm hex wrenches and a straight blade screwdriver. Weight: 92 grams.

**F. IB-2**



**F. IB-2 I-Beam Mini Fold Up Hex Wrench/Screwdriver/Star Driver Set**

The IB-2 features our unique I-Beam handle with 1.5, 2, 2.5, 3, 4, 5, 6, & 8mm hex wrenches; a T25 Torx® compatible star-shaped driver; and a straight blade screwdriver. Strong, compact, and lightweight, the IB-2 is a great tool for taking on the road or trail. Weight: 111 grams.

**FREE CUSTOMIZING**

Ask your distributor about our custom laser-engraving program. Your shop name or logo permanently engraved for free on IB-1, IB-2, IB-11 and IB-12 I-Beam Tools or UK-1 Utility Knife with a qualifying order.



**G. IB-11**



**G. IB-11 Low Profile I-Beam Mini Tool**

Slim, light and compact, the IB-11 is 28% lighter than the IB-1 yet features the same tools. Each micro sized hex bit is forged for strength and longevity, then bolted solidly to our world famous forged I-beam center beam. 3, 4, 5, 6 and 8mm hex wrenches and a straight blade screwdriver. Weight: 66 grams.

**H. IB-12**



**H. IB-12 Low Profile I-Beam Mini Tool**

Similar in construction to the IB-11, the IB-12 is the slimmer, lighter sister of the IB-2. 2, 2.5, 3, 4, 5, 6 and 8mm hex wrenches along with a T25 Torx® compatible star-shaped driver and a straight blade screwdriver. Weight: 79 grams.

**I. IB-3**



**I. IB-3 I-Beam Mini Fold-Up with Chain Tool**

A complete take-along tool combining our award winning I-Beam technology with a full complement of emergency tools. The IB-3 includes all the tools included in the IB-2 plus a composite wrapped tire lever, spoke wrenches and a 10-speed compatible chain tool. A portable workshop designed to get you back on the bike!

IB-1, IB-2, IB-3, IB-11, and IB-12

Patented:  
US 7,140,280  
US 6,880,435  
US D515,391  
TW 1241970  
TW D105522



**A. PH-1**

**A. PH-1 P-Handled Hex Wrench Set with Holder**

Engineered for fit, function and leverage, these L-shaped shop quality wrenches are a must have for every workshop.

**Features:**

- High torque, industrial steel hexes. Straight hex shaft on the short side, Balldriver® on the long side
- Includes 2, 2.5, 3, 4, 5, 6, 8 and 10mm
- Precision chamfered tips for a clean tight fit
- Comfortable, ergonomically designed nylon handles fit perfectly in your hand
- Durable wall/bench mount tool holder allows easy access and organization

**Individual sizes available separately**

- **PH-2:** 2mm
- **PH-2.5:** 2.5mm
- **PH-3:** 3mm
- **PH-4:** 4mm
- **PH-5:** 5mm
- **PH-6:** 6mm
- **PH-8:** 8mm
- **PH-10:** 10mm
- **PH-11:** 11mm
- **PH-12:** 12mm



**E. HXS-2.2**

**B. HXS-1.2**

**B. HXS-1.2 Professional L-Shaped Hex Wrench Set**

Shop quality L-shaped, high torque industrial steel Balldriver® hex wrenches. Featuring chamfered tips, tight tolerances and a handy portable tool holder, hinged for easy access. 1.5, 2, 2.5, 3, 4, 5, 6, 8 and 10mm hexes.

**Note:** 10mm hex in set is not a Balldriver®.



**C. HR-8 Hex Wrench**

A long handled 8mm L-Wrench with Balldriver® individually packaged for retail sale or shop use. Ideal for installing and removing crank bolts.

**D. HR-11 / HR-12 / HR-14 11mm, 12mm & 14mm Hex Wrenches**

11mm, 12mm, and 14mm hex wrenches are necessary for removing the freehub bodies from several popular brands of hubs (Mavic®, Sun Race®, Sovos®, and others). Park Tool HR-11, HR-12, and HR-14 are through hardened industrial quality steel with chamfered tips for a precision fit.



**E. HXS-2.2 Professional L-Shaped Hex Wrench Set with Holder**

Shop quality L-shaped, high torque industrial steel Balldriver® hex wrenches featuring 2, 2.5, 3, 4, 5, 6, 8 and 10mm hex wrenches with chamfered tips and tight tolerances. Bench/wall mount tool holder included.

**Note:** 10mm hex in set is not a Balldriver®.

**F. HT-6 • HT-8 • HT-10**



**F. HT-6 / HT-8 / HT-10 Hex Tools**

Specially designed for cranks, free hubs and pedals the HT tools are built for speed, leverage and comfort. Our dual density, ergonomically designed screwdriver handle molded over an extra long, extra deep, super strong hex. It may be your new favorite tool!

- HT-6: 6mm
- HT-8: 8mm
- HT-10: 10mm

Park Tool Fold Up Hex Wrench Sets use a multi-position composite handle that is comfortable, lightweight, slip-resistant, and 40% stronger than steel handles. Hexes are made from industrial tool steel, through hardened and tempered for long life.

**G. AWS-12**

2mm, 3mm, 4mm, 5mm, 6mm, 3/16", 7/32", & 1/4" Hex Wrench Set

**G. AWS-12**



**H. AWS-11**

3mm, 4mm, 5mm, 6mm, 8mm, & 10mm Hex Wrench Set

**H. AWS-11**



**I. AWS-10**

1.5mm, 2mm, 2.5mm, 3mm, 4mm, 5mm, & 6mm Hex Wrench Set

**I. AWS-10**



**J. AWS-9**

4mm, 5mm, and 6mm Hex Wrench Set with Phillips and straight blade screwdrivers

**J. AWS-9**





A. **AWS-15**

Park Tool introduced the bicycle world to the three-way hex wrench set over 30 years ago. Our Y shaped wrenches fit perfectly in the palm of your hand and provide tremendous leverage making them a favorite of thousands of shop mechanics worldwide. A glass injected composite center and industrial strength, heat treated steel hexes help make this tool the best selling 3-way in the industry. Now available in five configurations. Re-engineered in 2012 to be stronger and more comfortable in the hand!

**A. AWS-15 Aluminum Body 3-Way Hex Set**

Featuring a forged, two-piece anodized, ergonomically designed aluminum body and replaceable hex wrenches. Hexes are made from industrial strength, heat treated Protanium® steel and plated for long life.

**B. AWS-1**

4mm, 5mm, & 6mm Hex Wrench Set

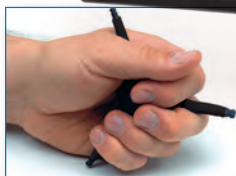

B. **AWS-1**

**C. AWS-3 (not pictured)**

2mm, 2.5mm, & 3mm Hex Wrench Set

**D. AWS-7 (not pictured)**

Hex/Torx® Compatible Y-Wrench 4mm, 5mm hex and T25

**E. AWS-8**

4mm, 5mm, & 6mm Hex Wrench Set with balldriver tips

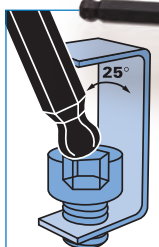

E. **AWS-8**

**F. ST-3 3-Way Socket Wrench**

The three most common bolt and nut sizes are combined with the classic Park Tool 3-way "Y" body. 8mm, 9mm, and 10mm forged chrome vanadium steel sockets.



F. **ST-3**



G. PH-T1

### G. PH-T1 P-Handled Torx® Compatible Star Shaped Driver Set

A complete set of Star-shaped wrenches to fit Torx®-style fasteners, the PHT wrenches feature our proprietary “P” handles, designed for comfort, control and leverage. Made from high torque industrial steel and through hardened for long life, the set of eight includes the following sized wrenches: T6, T8, T10, T15, T20, T25, T30 and T40.

Individual sizes available separately

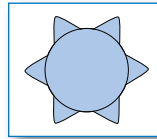

- PH-T6: T6
- PH-T8: T8
- PH-T10: T10
- PH-T15: T15
- PH-T20: T20
- PH-T25: T25
- PH-T30: T30
- PH-T40: T40

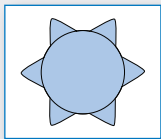

H. TWS-3

### H. TWS-3 Torx® Compatible Y Wrench

T10, T25 and T30 in our classic “Y” design.

I. TWS-2

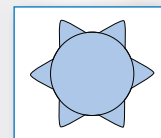

### I. TWS-2 Torx® Compatible Star-Shaped Driver Set

The TWS-2 includes the star-shaped wrench sizes currently being used on components such as disc brakes, pedals and chain rings (T7, T9, T10, T15, T20, T25, T27, T30 and T40) in a convenient fold-up set.

## A. SCW-13 through SCW-28 Shop Cone Wrenches

The standard of the industry, Park Tool Shop Cone Wrenches are unmatched in quality and performance. The special "Y" head design puts more material where it's needed for strength and durability. Precision sizing and a military grade industrial phosphate finish ensure an accurate fit and consistent quality. Thin enough to use on the narrowest of adjusting cones, the SCW Shop Cone Wrenches have a long, vinyl dipped handle for leverage and comfortable use. Sizes 13-24, 26 & 28mm.

Individual sizes available separately

- **SCW-13:** 13mm
- **SCW-14:** 14mm
- **SCW-15:** 15mm
- **SCW-16:** 16mm
- **SCW-17:** 17mm
- **SCW-18:** 18mm
- **SCW-19:** 19mm
- **SCW-20:** 20mm
- **SCW-21:** 21mm  
(Fits centering flats on some U-brakes)
- **SCW-22:** 22mm
- **SCW-23:** 23mm
- **SCW-24:** 24mm  
(Fits suspension fork top caps)
- **SCW-26:** 26mm
- **SCW-28:** 28mm

### A. SCW



## B. SCW-SET.3 Shop Cone Wrench Set

Includes 13mm through 24mm, 26mm and 28mm SCW wrenches.

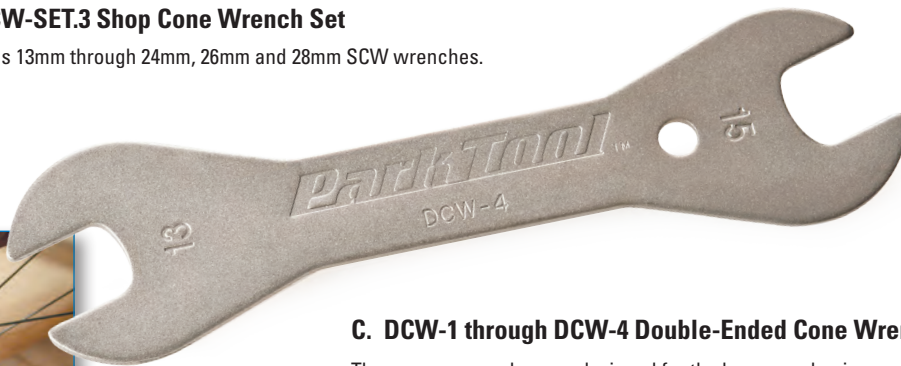

### C. DCW

## C. DCW-1 through DCW-4 Double-Ended Cone Wrenches

These cone wrenches are designed for the home mechanic or occasional user. They're made of thin steel and are nickel plated and heat treated for long use. Available in four popular sizes from 13mm to 18mm. Their small size makes them ideal to carry along for quick repairs.

- **DCW-1:** 13mm & 14mm
- **DCW-2:** 15mm & 16mm
- **DCW-3:** 17mm & 18mm
- **DCW-4:** 13mm & 15mm

## D. HCW-17 Fixed-Gear Lockring Tool

Two different radius hooks to fit most fixed-gear lockrings and some BMX freewheel lockrings.



### D. HCW-17

### E. AV-1



## E. AV-1 Axle Vise

This tool holds the axle so it will not turn while work is done on the hub. It has two different diameter receptacles so it will work on front and rear axles. It is simple to use - just insert the axle into the proper diameter opening and tighten the bench vise. The jaws will open automatically when the vise is opened.



### F. AV-5

## F. AV-5 Axle and Spindle Vise Inserts

A great shop accessory made to hold a wide variety of axles, spindles and any Park Tool Freewheel Remover/Locking Tool. Made from precision extruded aluminum these vise inserts include top retainer legs and magnets that make for easy bench vise use. The AV-5 features the following jaw openings: 5, 9, 10, 12, 14, 20, 25, 30, and 36mm, plus a mini v-block and a 1" hex.







G. SR-1 • SR-11 • SR-18

**G. SR-1 / SR-11 / SR-18 Sprocket Remover/Chain Whip**

This combination chain whip and freewheel / locking remover wrench is heat treated to prevent bending and flexing. It also features hardened pins to keep the chain in place and a comfortable handle. Hex opening fits Park Tool freewheel removers.

- **SR-1:** Fits all 5 to 10 speed cassettes and freewheels
- **SR-11:** Fits 5 to 11 speed cassettes
- **SR-18:** Fits 1/8" fixed gear sprockets

H. SR-2.2



**H. SR-2.2 Sprocket Remover/Chain Whip**

This shop quality chain whip gives you incredible leverage without worry of slippage. Heavy duty, heat treated head with a round vinyl coated handle. Hardened bolts hold securely and make chain replacement easy. Fits 5 to 11 speed cassettes.



I. FRW-1

**I. FRW-1 Freewheel Remover Wrench**

This tool securely holds freewheel and locking tools (FR-1 through FR-8, BBT-5/FR-11) for removal and installation. Features an investment cast head and a long, round, vinyl dipped handle for superior leverage.

J. HCW-16



**J. HCW-16 Chain Whip/15mm Pedal Wrench**

A great combination for the home or traveling mechanic. Fits 5 to 10 speed cassettes.

**K. FR-1 through FR-11 Freewheel Removers**

Heat treated alloy steel, one inch base fits wrench or bench vise. Thin wall construction allows use without removal of cones and locknuts on most hubs.



Fits Shimano®, Sachs® Aris®, and SunRace®. DNP Epoch and 5-9 speed freewheels.

FR-1.2



Fits Sun Tour® two-notch freewheels. Not recommended for Sun Tour® four to six notch freewheels.

FR-2



Fits all Sun Tour® four-notch freewheels since 1986.

FR-3



Fits Atom®, Regina®, splined Zeus®, and some Schwinn® Approved freewheels.

FR-4



Fits Shimano®, SRAM®, SunRace®, SunTour®, Chris King® and other cassette lockrings. Also fits some Shimano® disc brake lockrings.

FR-5



Removes four-notch BMX / single-speed freewheels from hubs with 1.37 x 24 TPI threads.

FR-6



Fits Shimano®, SRAM®, SunRace®, SunTour®, Chris King® and other cassette lockrings. Also fits some Shimano® disc brake lockrings. Guide pin stabilizes tool.

FR-5G



Fits Falcon® freewheels.

FR-7



Removes four-notch freewheels from "flip-flop" BMX hubs with 30 x 1mm threads.

FR-8



Removes and installs all Campagnolo® cassette lockrings (including 11-speed) and splined, 12-tooth Campagnolo® bottom bracket cups.

BBT-5/FR-11



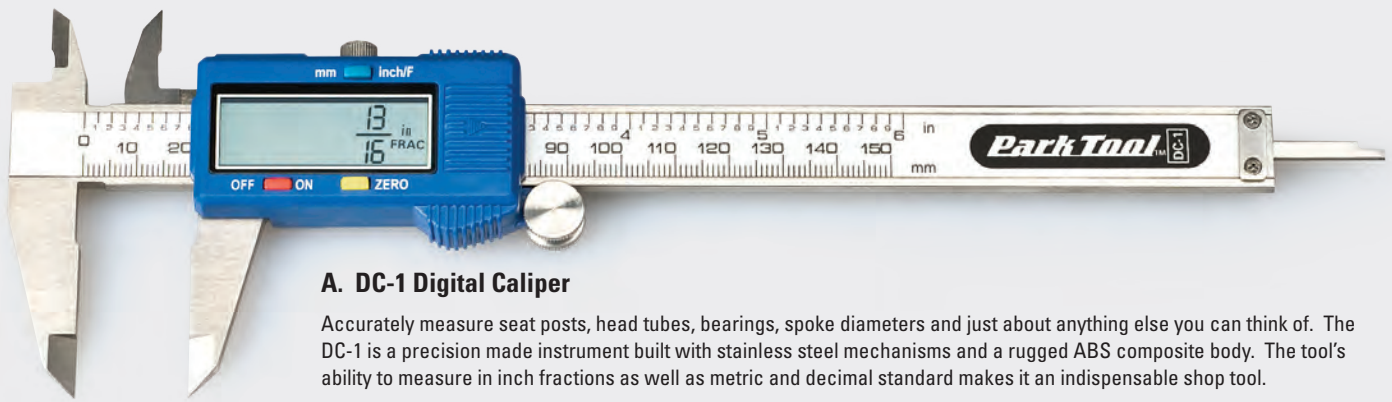

A. DC-1

### A. DC-1 Digital Caliper

Accurately measure seat posts, head tubes, bearings, spoke diameters and just about anything else you can think of. The DC-1 is a precision made instrument built with stainless steel mechanisms and a rugged ABS composite body. The tool's ability to measure in inch fractions as well as metric and decimal standard makes it an indispensable shop tool.

**Features:**

- Large LCD display
- Display metric, decimal standard and fractional standard to 1/128"
- Measures external, internal, depth and stepped dimensions
- Resolution: +/- 0.01mm/0.0005"/1/128"
- Accuracy: +/- 0.02mm/0.001 (-100mm)
- Repeatability: +/- 0.01mm/0.0005"
- Protective case and battery included

B. DS-2



### B. DS-2 Tabletop Digital Scale

Commonly called a Gram Scale, this highly accurate tabletop scale is perfect for weighing small parts and components in grams or ounces.

**Features:**

- Accurate to within 2g/ 1000g, 2g/ 2000g, 3g/ 3000g
- Tare feature to exclude weight of container
- Switches easily between grams and ounces
- 3000 gram (106 oz) capacity
- Battery included

C. DS-1



### C. DS-1 Digital Scale

A versatile digital scale built to accurately weigh bikes, frames, and components. Uniquely designed to be clamped solidly into a repair stand or hung from a hook or branch. Measures in pounds to the ounce and kilograms to the hundredth. Includes a dual position, silicone coated hanging hook.

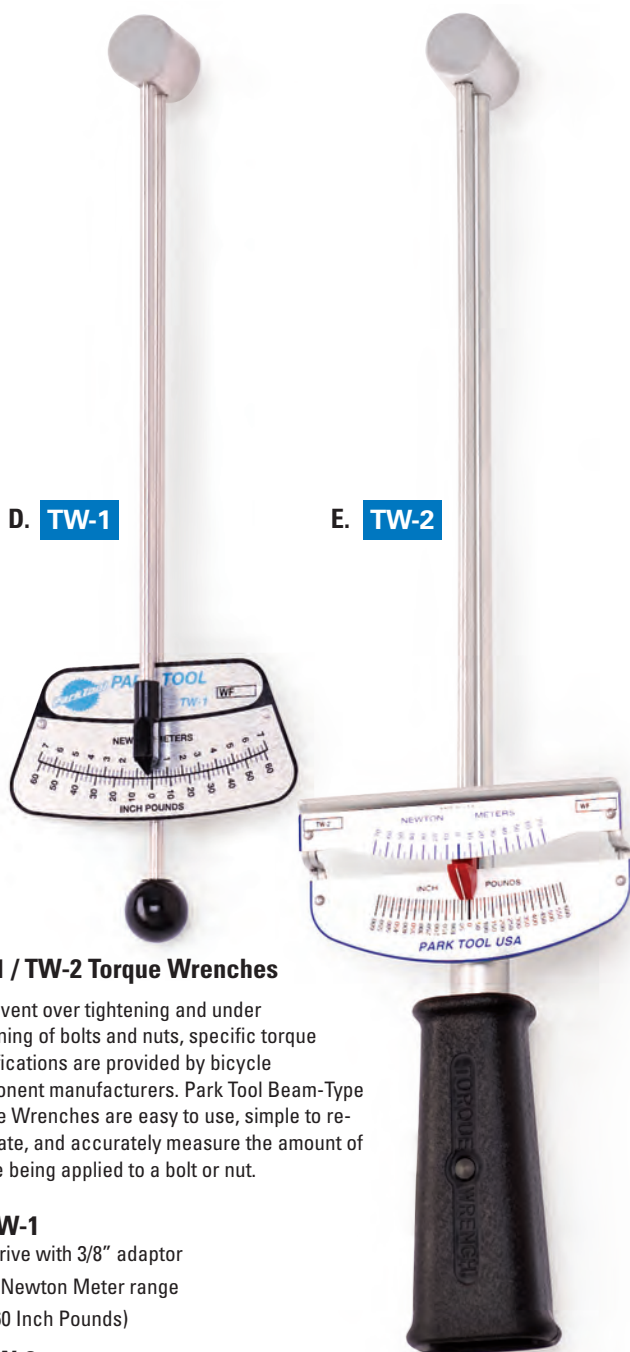

D. TW-1

E. TW-2

### TW-1 / TW-2 Torque Wrenches

To prevent over tightening and under tightening of bolts and nuts, specific torque specifications are provided by bicycle component manufacturers. Park Tool Beam-Type Torque Wrenches are easy to use, simple to recalibrate, and accurately measure the amount of torque being applied to a bolt or nut.

#### D. TW-1

- 1/4" drive with 3/8" adaptor
- 0 - 7 Newton Meter range
- (0 - 60 Inch Pounds)

#### E. TW-2

- 3/8" drive
- 0 - 70 Newton Meter range
- (0 - 600 Inch Pounds)



F. TW-5



### TW-5 / TW-6 Ratcheting "Click-Type" Torque Wrenches

High quality, ratcheting torque wrenches to quickly and accurately measure and apply the proper amount of torque to components and accessories. The TW-5 and TW-6 feature a dial-adjust "click" system to preset the desired torque setting.

**Note:** The TW-5 is a precision measuring instrument designed to be used to measure lower torque settings. At NO TIME should the TW-5 be used for torque applications higher than 15 Newton Meters (132 inch pounds) or used as a substitute for a ratcheting wrench.

#### F. TW-5

- Ratcheting 1/4" drive fitting with 3/8" adaptor
- 3-15 Newton Meter (26-132 inch pounds) range
- 19.5cm (7-1/2") length
- Protective case included
- Ratchets and measures torque in both left and right directions

#### G. TW-6

- Ratcheting 3/8" drive fitting
- 10-60 Newton Meter (88-530 inch pounds) range
- 38cm (15") length
- Protective case included
- Ratchets and measures torque in both left and right directions



G. TW-6

### H. SBS-1 Socket & Bit Set

The SBS-1 is a complete, shop quality set of the most common 3/8" drive chrome vanadium sockets, hex bits and Torx® style bits. The set includes a convenient holder and the following tools:

- Sockets: 8, 9, 10, 11, 12, 13, 14, 15mm and 1" (fits various Park Tool freewheel, locking and bottom bracket tools)
- Hex bits: 3, 4, 5, 6, 8 and 10mm
- Torx® style bits: T25, T30 and T40

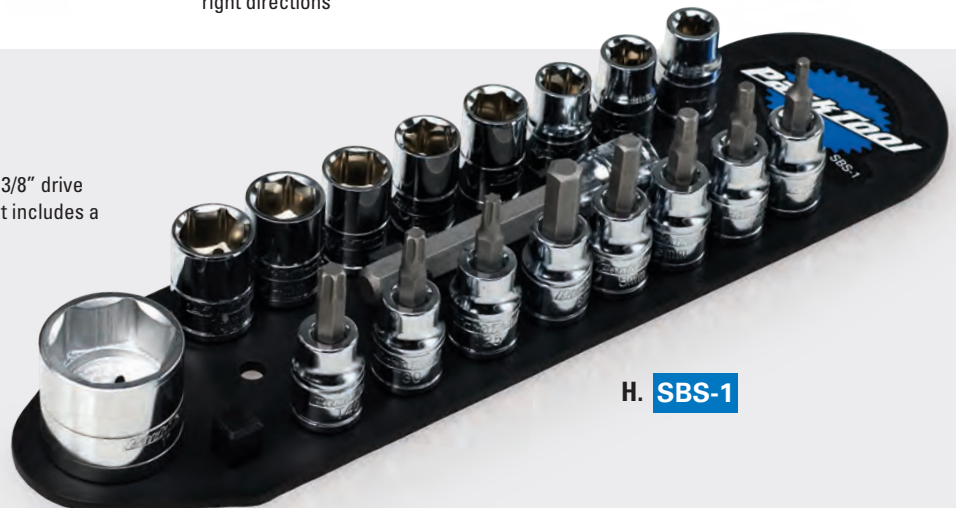

H. SBS-1

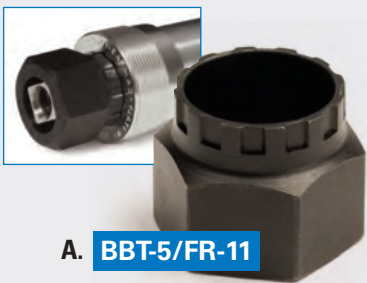

A. **BBT-5/FR-11**

**A. BBT-5/FR-11 Bottom Bracket/Cassette Tool for Campagnolo®**

Removes and installs all Campagnolo® cassette lockrings (including 11-speed) and splined, 12-tooth Campagnolo® bottom bracket cups.



B. **BBT-18**

**B. BBT-18 Bottom Bracket Tool**

The BBT-18 is a heavy duty, investment cast tool for installing and removing all Shimano®, SRAM®, and ISIS® Drive eight-notch bottom bracket cups. 36mm wrench flats.



C. **BBT-32**

**C. BBT-32 Compact Bottom Bracket Tool**

Economical and compact, this version of the BBT-22 tool is perfect for the home mechanic. The BBT-32 installs and removes Shimano® and ISIS® Drive 20-tooth splined bottom bracket cups and features 32mm wrench flats.



D. **BBT-10**

**D. BBT-10 Adjusting Cap Tool**

Steel, investment cast tool designed to remove and install the adjusting caps on Shimano® Hollowtech® II crank/bottom bracket systems. The BBT-10 is a shop quality tool with good leverage including an 8mm wrench option to help remove seized caps.

**E. BBT-19 Bottom Bracket Tool**

The BBT-19 is a heavy duty, shop quality tool for installing and removing Shimano®, SRAM®, Truvativ®, Race Face®, FSA®, and Campagnolo® 16-notch external bearing bottom bracket cups with an outside diameter of 44mm. Made from investment cast steel, the BBT-19 can be turned with a 3/8" drive torque wrench, 3/8" ratchet driver, 1" wrench, or FRW-1 Freewheel Remover Wrench.



E. **BBT-19**

**F. BBT-22 Bottom Bracket Tool**

The BBT-22 is a shop quality tool for installing and removing Shimano® and ISIS® Drive splined 20-tooth bottom bracket cups. Made from investment cast steel, the BBT-22 utilizes a flat tooth profile to ensure maximum engagement with the bottom bracket cup. Can be turned with a 3/8" drive torque wrench, 3/8" ratchet driver, 32mm wrench, 1" wrench, or FRW-1 Freewheel Remover Wrench.



F. **BBT-22**



G. **SPA-1 • SPA-2**

**G. SPA-1 / SPA-2 Pin Spanners**

Park Tool Pin Spanners have been designed to give maximum usefulness and versatility at the lowest possible cost. Tough, high carbon steel is used on each tool to ensure long life. Handle is vinyl coated to give a good grip. Each Pin Spanner is color coated for easy recognition.

• **SPA-1 (Green):** Fits adjusting cup on most 3-piece cranks

• **SPA-2 (Red):** Fits one-key release dust caps and adjusting cone on most freewheels



H. **SPA-6**

**H. SPA-6 Adjustable Spanner**

This spanner uses hardened, replaceable pins. Designed for heavy-duty use, the distance between pins is adjustable, allowing use on virtually any hanger cup. Replacement Pins: 1501



I. **HCW-4**

J. **HCW-5**

K. **HCW-11**

**Crank & Bottom Bracket Wrenches**

I. **HCW-4:** 36mm box-end and bottom bracket pin spanner

J. **HCW-5:** Double sided bottom bracket locking hook spanner

K. **HCW-11:** Fits "slotted" bottom bracket adjusting cups and cups with "raised" 16mm wrench flats

L. **1501:** Replacement pins for HCW-4

### M. BBT-4 Bottom Bracket Tool

The BBT-4 is made for the installation and removal of 6-notch cartridge cups used on Campagnolo® Veloce®, Mirage®, Centaur®, Daytona® and Avanti® sealed cartridge bottom brackets. The handle is vinyl coated for comfort.



M. BBT-4

### N. BBT-7 Lockring Wrench

The BBT-7 Lockring Wrench is used for installing and removing the lockring used on Dura Ace® 7700 and XTR® 950 Bottom Brackets. It is laser cut and engages five of the lockring's six notches for a precise, secure fit. The handle is vinyl dipped for comfort. While made specifically to fit Dura Ace® and XTR® Lockrings, it also fits several other lockrings as well.



N. BBT-7

### O. BBT-9 Bottom Bracket Tool

The BBT-9 is used to remove and install Shimano®, Race Face®, FSA®, Truvativ®, SRAM®, Campagnolo®, and similar bottom bracket cups with 16 external notches and an outside diameter of 44mm. The BBT-9 is also used to remove and install 8-point Shimano® Hollowtech® II crank arm adjusting caps.



O. BBT-9

### P. BBT-29 Bottom Bracket Tool

New wrench for new sizes, compatible with Shimano® Dura-Ace 9000 series and XTR 980 series threaded bottom brackets as well as with FSA® MegaEvo threaded bottom brackets.



P. BBT-29

### Q. BBT-30.3 Bottom Bracket Bearing Tool Set

Designed and built to install and remove BB30 bearings. The BBT-30.3 features a bushing set used in conjunction with a head cup press to quickly and precisely press the BB30 and PF30 bearings into the bottom bracket shell. The included BB30 bearing remover works from inside the shell to easily push out bearings. Updated in 2012 to also remove PressFit 30 (PF30), EVO 386, and BBright™.



Q. BBT-30.3

### R. BBT-90.3 Press Fit Bottom Bracket Bearing Tool Set

The BBT-90.3 is designed to remove and install the bearings and press fit bearing units used in BB90, BB92, Shimano® press fit, SRAM® press fit GXP, Race Face® press fit and other press fit bottom bracket systems. Includes a bearing removal tool, which slides through and expands behind the bearing so it can be tapped out with a hammer. Also includes two bearing installation bushings, which are used in conjunction with an HHP-2 or HHP-3 Head Cup Press to press the bearings into the bottom bracket shell.



R. BBT-90.3

### S. 752 Reamer & Spacer Set For BB30 Bottom Bracket Shells

Used to ream BB30 bottom bracket shells to an ID of 41.94mm. Must be used with the HTR-1 Head Tube Reamer and Facer and a 750.2 Centering Cone.



S. 752

### T. 791 Reamer & Pilot Set for PF30 Bottom Bracket Shells

Used to ream and face PF30 bottom bracket shells to an ID of 45.94mm. Must be used with the HTR-1 Head Tube Reamer and Facer, 750.2 Centering Cone and the 690-XL Facer.



T. 791

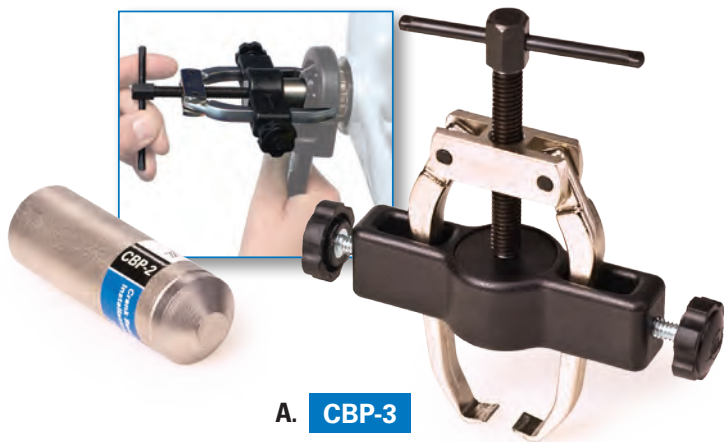

A. **CBP-3**

### A. CBP-3 Campagnolo® Bearing Puller and Bearing Installation Set

Designed and built to install and remove the pressed bearing from Campagnolo® and Fulcrum® Ultra-Torque® cranks. The forged arms of the puller feature tapered edges that securely pinch under the bearing while the heavy duty plunger system “pulls” the bearing. The installation tool accurately fits both the crank spindle and the press fit bearing to ensure safe, accurate installation. Just tap the bearing into place using the tool and a hammer.



E. **CBP-5**

### E. CBP-5 Campagnolo® Power-Torque™ Crank and Bearing Adaptor Set

Used to remove and install Power-Torque™ crank arms and crank bearings.

**The CBP-5 includes:**

- Crank and crank bearing removal adaptor used with the Park Tool CBP-1 (part of CBP-3 set) Bearing Puller
- Power-Torque™ bearing setter
- Removal pads for use with carbon crank arms
- Removal adaptor for use with aluminum crank arms
- Crank removal extension plug



B. **CCP-22**

### B. CCP-22 Crank Puller

A favorite of shop mechanics for over 30 years, the CCP-22 removes cranks using a square taper, Power Drive®, or Power Spline® bottom bracket interface. A long, comfortable, built-in handle and fine thread provide the leverage needed to remove even the tightest cranks. Designed with a rotating tip to ensure smooth operation and long life.



C. **CCP-44**

### C. CCP-44 Crank Puller

The CCP-44 is specifically designed to remove cranks using an Octalink® or ISIS® Drive bottom bracket interface. Uses a comfortable handle, fine thread, and a special rotating tip for superior leverage, smooth operation, and years of trouble-free service.



F. **CNW-2**

### F. CNW-2 Chainring Nut Wrench

The CNW-2 makes chainring bolt set installation and removal easy. It securely holds the slotted nut to prevent spinning when tightening or loosening the bolt. Double-ended to fit most slotted-type nuts.



G. **CCW-5**

### G. CCW-5 Crank Bolt Wrench

The CCW-5 features both 14mm socket and 8mm hex wrench on a long, comfortable handle.



D. **CWP-7**

### D. CWP-7 Compact Crank Puller

Includes two rotating tips (11.3mm and 16.3mm) and built in wrench flats allowing the tool to remove cranks using a square taper, Octalink®, ISIS® Drive, Power Drive® or Power Spline® bottom bracket interface.



H. **TAP-3 • TAP-6**

### H. TAP-3 / TAP-6 Pedal Taps

Clean out or restore damaged threads in crank arms with these pedal taps. These taps can be used with either steel or alloy crank arms and are available in two popular sizes: 1/2" and 9/16" in both right and left-hand threads. Made of high carbon steel, precision ground, and hardened to stay sharp, they cut easily and fit all conventional tap handles.

- **TAP-3:** Set of 2, 1/2" x 20 Left and Right
- **TAP-6:** Set of 2, 9/16" x 20 Left and Right

I. DP-1



### I. DP-1 Friction Fit Dummy Pedal

A quick and easy way to make derailleur adjustments during assembly or repair without installing a pedal.

J. DP-2



### J. DP-2 Threaded Dummy Pedal

Similar to the DP-1 but threaded for positive drive side engagement.

K. CDG-2

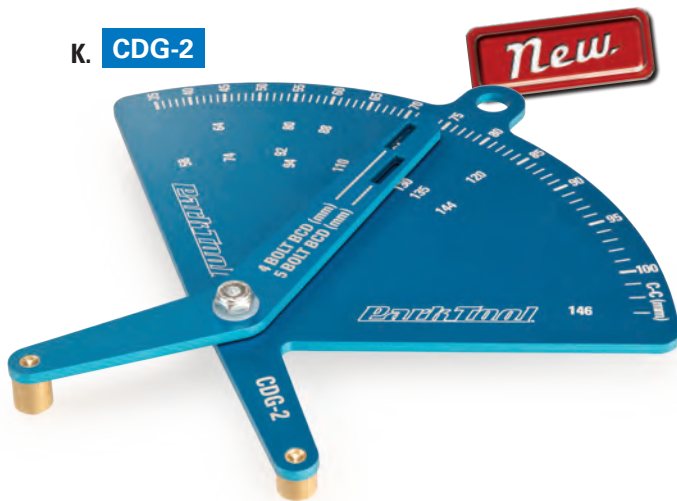

### K. CDG-2 Chaining Diameter Gauge

The CDG-2 easily and accurately measures bolt circle diameter (BCD) in millimeter for a wide variety of four and five bolt chaining patterns. Made of anodized aluminum and permanently laser engraved, the tool centers itself in chaining holes, chaining bolts or crank arm holes. The CDG-2 also includes a center to center distance scale and a handy reference chart listing additional mounting pattern measurements.

M. PW-4



L. PW-3



N. PW-5



### L. PW-3 Pedal Wrench

Made from Cro-Moly steel for a shop quality pedal wrench made to last. 15mm and 9/16" precision openings and a long, round, vinyl dipped handle that won't dig into your hand like flat pedal wrenches.



### M. PW-4 Professional Pedal Wrench

The PW-4 Professional Pedal Wrench is designed for heavy shop use. Two 15mm wrench openings are oriented at 30 degree and 45 degree angles so the user can always achieve the best mechanical advantage, regardless of the pedal position. An oversized, asymmetrical head is made from Cro-Moly steel for superior strength and durability. While strong, the PW-4 is thin enough to access all wrench flats. An extra long 14" handle provides the leverage to remove even the tightest pedals. The handle is round and vinyl dipped so it won't dig into the hand like flat wrenches.



### N. PW-5 Home Mechanic Pedal Wrench

Designed for the do-it-yourself mechanic or rider, the PW-5 is perfect to take along or for the home workshop. Although economically priced, this 15mm pedal wrench, like all Park Tool products is built to last. Made from heat-treated spring steel and vinyl dipped for comfort, the PW-5 is 11-1/2" (29 cm) long.





A. DT-1.2



**A. DT-1.2 Disc Tab Mount Facing Tool**

In order to ensure disc brakes function smoothly and accurately, the frame's mounting tabs must be parallel with the brake pads and rotor. The DT-1.2 is designed to perfectly machine the face of each tab, removing paint and material to create a flat surface. Works on forks with 100mm open dropouts and forks with closed dropouts using 20mm thru axles. Works on frames with 135mm open dropouts and frames with closed dropouts using 12mm thru axles in 135mm, 142mm and 150mm lengths.

**B. DT-UK Disc Tab and Post Mount Facing Tool Upgrade Kit**

A five piece kit (two axles, two end caps and a c-clip) that upgrades DT-1 and DT-4 tools to make them compatible with newer Maxle and QR style thru axles.

**Note:** Not needed for DT-1.2 and DT-4.2



C. DT-2



**C. DT-2 Rotor Truing Fork**

Specially designed, and precisely manufactured to gently adjust bent or damaged brake rotors. Each DT-2 features two different slot depths laser cut from high quality steel. Center handle is vinyl dipped for comfort.

D. PP-1.2



**D. PP-1.2 Hydraulic Brake Piston Press**

The unique shape and size of the PP-1.2 is perfect for compressing the hydraulic piston by pushing the brake pads apart to speed service and pad replacement. Slide the polished, wedge-shaped tool between pads to expand the gap and pre-set the pistons into the caliper. Now slightly narrower than the original PP-1 to fit a wider variety of brakes.





E. DT-3

**E. DT-3 Rotor Truing Gauge**

Accurately gauge the straightness of disc brake rotors while the wheel is mounted in a TS-2.2 Professional Wheel Truing Stand. The DT-3 features an infinitely adjustable, finely threaded indicator gauge. Works with any diameter brake rotor.



F. DT-3i

**F. DT-3i Dial Indicator for DT-3**

Dial Indicator Set bolts directly to the DT-3 allowing for greater accuracy and a way to measure results.



G. DT-4.2

**G. DT-4.2 Disc Post Mount Facing Tool**

Engineered and built to accurately face frame and fork mounted disc brake posts. The DT-4.2 machines the posts parallel with each other, perpendicular to the rotor and to an equal height. Works on forks with 100mm open dropouts and forks with closed dropouts using 15mm and 20mm thru axles. Works on frames with 135mm open dropouts and frames with closed dropouts using 12mm thru axles in 135mm, 142mm and 150mm lengths.



A. **CN-10**



**A. CN-10 Professional Cable & Housing Cutter**

The CN-10 Cable and Housing Cutter is a shop quality cutter designed specifically for use on all bicycle cables and housing, including hard-to-cut index housing. The CN-10 has cold forged, heat treated steel handles for strength and precision ground cutting jaws for a clean cut on every cable. Dual density molded grips are specially contoured for superior comfort and control. The CN-10 has a built in crimper for cable end caps and a forming hole for reforming housing ends and housing ferrules. A wire latch holds the handles together when not in use.



B. **OBW-4**

**B. OBW-4 Offset Brake Wrench**

A thin offset wrench with 10, 11, 12 and 13mm openings made to fit and adjust many models of side pull and dual pivot brakes.

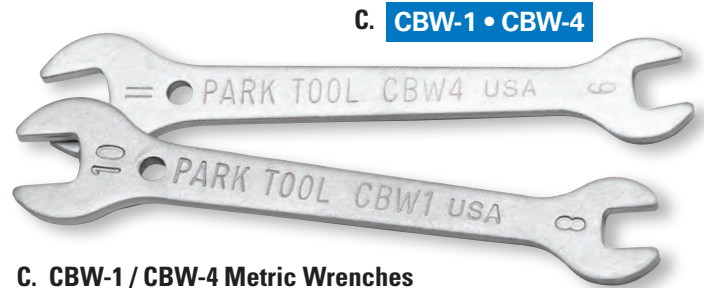

C. **CBW-1 • CBW-4**

**C. CBW-1 / CBW-4 Metric Wrenches**

These small, nickel plated wrenches can be used on brakes, derailleurs, etc.

- **CBW-1:** 8mm open - 10mm open
- **CBW-4:** 9mm open - 11mm open

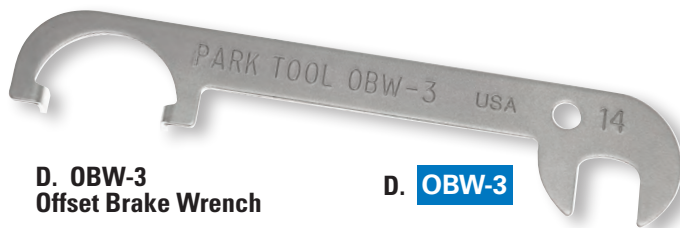

D. **OBW-3**

**D. OBW-3 Offset Brake Wrench**

We call this our offset wrench because of its unique design, which allows it to be used in tight places, such as centering caliper brakes. OBW-3 has a 14mm opening, and the other end fits into the tension springs to rotate the brake on its bolt.



E. **BT-2**

**E. BT-2 Cable Stretcher**

Commonly referred to as a "4th Hand", the Park Tool Cable Stretcher pulls cables tight. It features one-hand operation with a thumb lock to hold the cable tight while your hand is removed to tighten pull-up bolts and nuts. Made from heat treated steel, chrome plated, and featuring cushion grips for comfort. A must for any shop, home or professional.



F. **NP-6**

**F. NP-6 Needle Nose Pliers**

Forged, heat-treated Cro-Moly steel professional quality 6" pliers. The NP-6 features an invisible spring, soft touch dual density grips and five different crimping/grasping areas as well as cutting blade.



G. **SP-7**

**G. SP-7 Side Cutter Pliers**

Forged, heat-treated Cro-Moly steel, professional quality 7" diagonal/ side cutting pliers featuring soft touch, dual density grips.

## H. BCB-4



### H. BCB-4 Bike Cleaning Brush Set

A clean bike looks great, performs better, lasts longer, and is easier to maintain. Now with the BCB-4 Bike Cleaning Brush Set, having a clean bike is easier than ever. The BCB-4 contains four brushes, each specially designed for a specific cleaning purpose: a double-ended gear cleaning brush, a tire and frame tube cleaning brush, a frame cleaning sponge brush, and a tapered detail brush. "Sure Grip" dual density handles insure a positive grip even with wet hands.

11-Speed  
Compatible



## I. GSC-1

### I. GSC-1 GearClean Brush

Park Tool's GearClean Brush has a unique design. A large comfortable handle with a curved, toothed-end reaches dirt deep between the gears, and tough nylon bristles clean the derailleur and chain. Saves wear and tear on your chain and freewheel. Works great on brakes or other places where dirt collects. 11 speed compatible. Handy size to take along for quick cleaning anywhere. Made of sturdy nylon.

## J. PPL-1 / PPL-2 PolyLube 1000 Lubricant

Park Tool's poly-urea lubricant was developed specifically for bicycle maintenance and repair. PolyLube 1000 has an extremely high shear strength to protect vital parts under extreme conditions. PolyLube 1000 also repels moisture and is compatible with conventional greases. Available in a handy 4 oz. tube (PPL-1) and a 16 oz. tub (PPL-2).



## J. PPL-1 • PPL-2

## K. CL-1 Synthetic Blend Chain Lube with PTFE

A chain lube from Park Tool, the leader in bicycle maintenance products. Using PTFE and a proprietary blend of oils, Park Tool Chain Lube works great in wet or dry conditions. It penetrates, reduces friction, prolongs component life, displaces moisture, and protects parts from rust and corrosion. Also works great on cables, spoke nipples, and derailleur and brake pivots.

4 oz. (118 mL) bottle



## K. CL-1



## L. SAC-2

### L. SAC-2 SuperGrip™ Carbon and Alloy Assembly Compound

Helps create a tighter grip between two slippery surfaces. Ideal for carbon, aluminum and steel seatposts, handlebars and stems. **Note:** Not for threaded surfaces.

4 oz. (113 g) tube



## M. ASC-1

### M. ASC-1 Anti-Seize Compound

Park Tool Anti-Seize Compound reduces friction in threaded and press fit connections for easy assembly and disassembly. Ideal for bottom bracket and pedal threads, pressed headset cups, seat posts, quill stems, etc. ASC-1 also seals and protects parts from corrosion and rust under the most extreme conditions. For use on steel, aluminum, and titanium.

4 oz. (113 g) tube

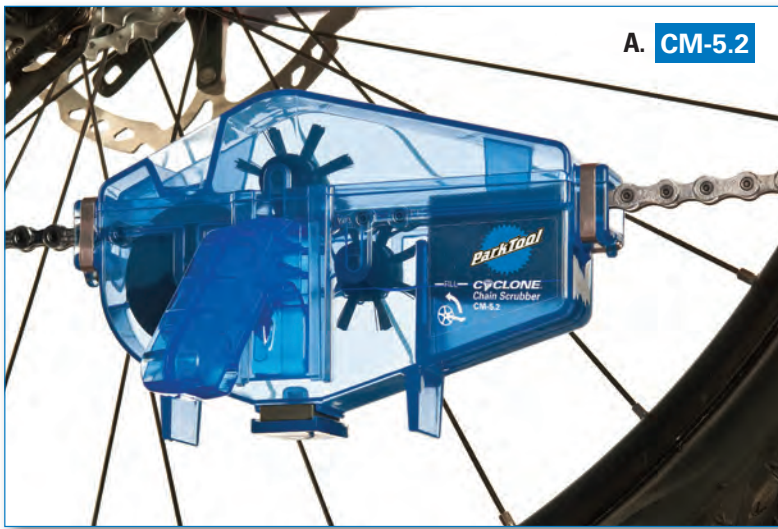

A. **CM-5.2**

### A. CM-5.2 Cyclone Chain Scrubber

The CM-5.2 Cyclone Chain Scrubber uses an extra large solvent reservoir and a series of rotating brushes to get chains really clean. A magnet at the bottom of the Cyclone's solvent reservoir draws particles scrubbed from the chain, effectively keeping them from being redistributed on the chain during cleaning. Durable sponge material draws solvent from the chain as it exits the Cyclone, reducing drips and mess. To make it easy to control and use, we've even added a handle. Works with all multi-speed bikes and some single-speed models.

### B. RBS-5 Replacement Brush Set for CM-5.2 (not pictured)

Includes a complete set of three rotating brushes plus two wicking sponges.



C. **CG-2.2**

### C. CG-2.2 Chain Gang Chain Cleaning System

A dirty drivetrain causes poor shifting and unnecessary wear to expensive parts. The Chain Gang contains everything needed to quickly and easily clean the chain, freewheel cogs, and chainrings. The Chain Gang includes a CM-5.2 Cyclone Chain Scrubber, a GSC-1 GearClean Brush, and an 8 oz. bottle of CB-2 Citrus Chain Brite. The CG-2.2 works on all derailleur bikes and many 3-speed and coaster brake bikes.



D. **CC-2**

### D. CC-2 Chain Checker

To alleviate poor shifting and uneven drive train wear, most manufacturers recommend chain replacement at or before 1% stretch. Now you can quickly and accurately determine the wear and stretch of any chain with the Park Tool Chain Checker. Simply insert the Chain Checker's pins into two links, press the swing arm gauge tight, and then check the gauge window for an accurate reading.



E. **CC-3.2**

### E. CC-3.2 Chain Checker

A worn chain shifts poorly and wears sprockets at an accelerated rate. The CC-3.2 is a "go, no go" gauge designed to accurately indicate when a chain reaches .5% and .75%, the points at which most chain manufacturers suggest replacement. The updated CC-3.2 is longer, more accurate and features permanent measurement markings.

### F. CB-2 Citrus ChainBrite

Biodegradable Citrus ChainBrite is specially formulated for use in the Cyclone Chain Scrubber. It quickly removes the toughest grease and grime buildup, yet won't harm alloy, plastic or rubber parts. Also works great as a general purpose parts cleaning fluid.

16 oz. (472mL) bottle

F. **CB-2**



G. **MG-2**



### G. MG-2 Nitrile Mechanics Gloves

Nitrile gloves keep hands free of grime and protected from potentially harmful chemicals and solvents. Improved in 2012 with a thicker, heavy-duty nitrile material, MG-2 Nitrile Gloves are tough enough to resist snags and able to be re-used multiple times. They provide superior fit and are easy to slip on and off. Sizes M, L, and XL.

Box of 100

### H. CT-5 Mini Chain Brute Chain Tool

This small chain tool goes anywhere and actually performs like a shop quality tool. The fine thread, special "V"-shaped handle, and super strong replaceable pin make chain removal and installation a breeze. The CT-5 works on any derailleur chain and has a "shelf" for loosening tight links. At only 77 grams, it's the perfect take-along chain tool.



H. CT-5

### I. CT-3.2 Chain Tool

A shop favorite updated to work on all chains including 1/8", 3/16" and 5 to 11-speed derailleur chains. The CT-3.2 features an adjustable locating shelf so it works on any width chain to remove and install chain rivets.

**Note:** CT-3.2 will notpeen Campagnolo® chain rivets (see CT-11).



I. CT-3.2

### J. CT-6.3 Folding Chain Tool with Peening Anvil

Now 11-speed compatible, the CT-6.3 removes and install chain pins in all derailleur chain. Smooth and powerful this handy take along is encased in a stainless steel shell, which becomes a comfortable handle when opened. Also included is a peening anvil that allows for peening of Campagnolo® 11-speed chains which pivots out of the way when not in use.

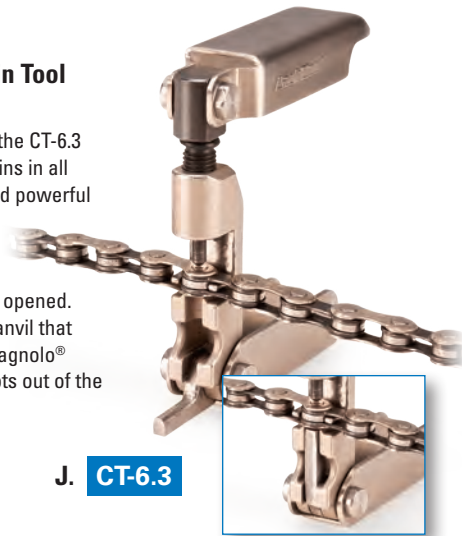

J. CT-6.3

### K. MLP-1.2 Master Link Plier

Many bicycle derailleur chains use a "master link" to separate the chain during removal and to join the chain during installation. While these master links can be removed and installed by hand, often times dirt, corrosion and wear can make the process difficult. MLP-1.2 Master Link Pliers make removal and installation of these master links quick and easy.



K. MLP-1.2



L. CT-4.3

### L. CT-4.3 Master Chain Tool with Peening Anvil

Specially designed to work with the tight tolerances and narrow profiles of 10 and 11 speed chains but also works on all other derailleur chain. The CT-4.3 is a powerful, precise tool designed to quickly and accurately remove and install chain rivets. Without a doubt the most accurate chain tool we've ever built!

- Integrated Link Pocket ensures precise alignment
- Replaceable, rotating pin
- Perfectly contoured cushioned handles
- Precisely machined investment cast body and components
- Includes removable anvil topeen Campagnolo® 11-speed chains

**Note:** The CT-4.3 is NOT compatible with Wipperman® chains.

### M. CTP Replacement Chain Tool Pin

These pins (not shown), fit Park Tool's CT-1, CT-2, CT-3, CT-3.2, CT-5 and CT-7 Chain Tools. Made from hardened alloy tool steel. Packaged carded in pairs: CTP-C Bulk: CTP

### N. CTP-4K Replacement Chain Tool Pin Kit for CT-4 / CT-4.2 / CT-4.3 / CT-11

Includes four replacement pins and one replacement bearing.



O. CT-11

### O. CT-11 Rivet Peening Tool for Campagnolo® 11-Speed Chain

After pressing the special connecting rivet into a Campagnolo® 11-Speed Chain and breaking off the pilot, Campagnolo® requires the end of the connecting rivet to be "peened" or "deformed" to prevent chain failure. The precision-machined CT-11 is used to accurately perform this critical process.

**Note:** The CT-11 will not install or remove chain rivets. Its sole function is topeen and secure the end of the Campagnolo® 11-speed connecting rivet. The Park Tool CT-4 or CT-4.2 Master Chain Tool is required for rivet installation and removal. The CT-4.3 Master Chain Tool has a built in peening function and does not require the use of a CT-11.

# Head Tube and Bottom Bracket Shell Cutters, Bushings and Pilots for HTR-1, HTR-1B, BTS-1 and BFS-1



## Tools Required for Machining Frame Bottom Bracket Shell

Bottom Bracket Standard	Bottom Bracket Shell Dimension	Required for Tapping and Facing	Required for Reaming and Facing	Required for Reaming Only	Required for Facing Only
Threaded English	33.7mm I.D.	BTS-1, 691, 692, 690	–	–	BFS-1 or BTS-1, 690, 681, 682
Threaded Italian	35mm I.D.	BTS-1, 693 (2 required), 690	–	–	BFS-1 or BTS-1, 688 (2 required), 690
BB30	42mm I.D.	–	HTR-1 or 1B, 752, 690-XL, 750.2	HTR-1 or 1B, 752, 750.2	–
PF30	46mm I.D.	–	HTR-1 or 1B, 752, 690-XL, 750.2	–	HTR-1 or 1B, 690-XL, 791P, 750.2
BBright Direct Fit	42mm I.D.	–	HTR-1 or 1B, 752, 690-XL, 750.2	HTR-1 or 1B, 752, 750.2	–
BBright Press Fit	46mm I.D.	–	HTR-1 or 1B, 752, 690-XL, 750.2	–	HTR-1 or 1B, 690-XL, 791P, 750.2
386 EVO	46mm I.D.	–	HTR-1 or 1B, 752, 690-XL, 750.2	–	HTR-1 or 1B, 690-XL, 791P, 750.2

## Tools Required for Machining Frame Head Tube

Headset Standard	Headset Cup Dimension	Frame Head Tube Dimensions	Required for Reaming and Facing	Required for Facing Only
1" External Cup–JIS	30.00 - 30.10mm O.D.	29.85 - 29.90mm I.D.	–	HTR-1 or 1B, 762, 690
1" External Cup–Professional	30.20 - 30.30mm O.D.	30.05 - 30.10mm I.D.	HTR-1 or 1B, 751.2, 690	HTR-1 or 1B, 763, 690
1-1/8" External Cup	34.05 - 34.15mm O.D.	33.90 - 33.95mm I.D.	HTR-1 or 1B, 754.2, 690	HTR-1 or 1B, 765, 690
1-1/4" External Cup	37.05 - 37.15mm O.D.	36.90 - 36.95mm I.D.	–	HTR-1 or 1B, 766, 690
1-1/2" External Cup	49.70 - 49.75mm O.D.	49.57 - 49.61mm I.D.	HTR-1 or 1B, 758.2, 750.2	HTR-1 or 1B, 767, 690-XL, 750.2
1-1/8" Internal Cup–ZS	44.05 - 44.10mm O.D.	43.95 - 44.00mm I.D.	HTR-1 or 1B, 788, 690-XL, 750.2	HTR-1 or 1B, 768, 690-XL, 750.2
1-1/2" Internal Cup–ZS	55.99 - 56.04mm O.D.	55.90 - 55.95mm I.D.	HTR-1 or 1B, 789, 690-XXL, 750.2	HTR-1 or 1B, 790, 690-XXL, 750.2
1-1/8" Integrated–IS Top	no cup	41.10 - 41.2mm I.D., 3.10 - 3.20mm Depth	HTR-1 or 1B, 756S, 750.2	–
1-1/8" Integrated–IS Bottom	no cup	41.10 - 41.2mm I.D., 6.90 - 7.0mm Depth	HTR-1 or 1B, 756S, 750.2	–
1-1/8" Integrated–Italian Top	no cup	41.95 - 42.05mm I.D., 2.8-3.0mm Depth	HTR-1 or 1B, 761S, 750.2	–
1-1/8" Integrated–Italian Bottom	no cup	41.95 - 42.05mm I.D., 6.60 - 6.80mm Depth	HTR-1 or 1B, 761S, 750.2	–

**Note:** The headset and bottom bracket standards listed in the tables on this page use head tubes and bottom bracket shells that can be machined using Park Tool products. This is not an exhaustive list of headset and bottom bracket standards used in the bicycle industry. Head tubes, headset parts, bottom bracket shells and bottom bracket parts should always be accurately measured to insure the correct tools are used.

## A. HTR-1 Head Tube Reaming & Facing Set

Proper frame preparation is very important. The HTR-1 combines reaming and facing of the head tube to create a perfect fit for most sizes of head cups. The HTR-1 comes complete with a 30.0mm reamer, #690 facer and four different size pilots (29.8mm, 30.0mm, 33.8mm, and 36.8mm). There are cases when a reamer is required to clean out or increase the diameter of the head tube. Most times however, facing of the head tube for good cup fit is the objective. In this case, reaming is not necessary and the pilots can be used in place of the reamers to keep the tool straight and create a faced head tube. The unique part of the HTR-1 is the quick-release, quick-adjust feature. The bottom portion can slide off and on easily without the long threading process. This portion of the tool can still be fine tuned while in use. The tapered centering cone unit rides on a bearing for extra smooth operation. All cutting surfaces are top quality and extra sharp.

## B. HTR-1B Head Tube Reaming & Facing Set

HTR-1B Includes 33.8mm reamer in place of 30.0 reamer.

## C. TAP-7 / TAP-8 / TAP-9 / TAP-10 Frame Taps

Frame Taps will become a lifesaver at some time for virtually every mechanic. As with all Park Tool Taps, these are made of high carbon steel and are precision ground. Park Tool Frame Taps cut easily and fit conventional tap handles.

- **TAP-7:** 3mm x .5, rear wheel drop-out alignment screws
- **TAP-8:** 5mm x .8, water bottle, toe clip, fender and rack bosses
- **TAP-9:** 6mm x 1, cantilever brakes and large fender bosses
- **TAP-10:** 10mm x 1, derailleur hanger



## D. TH-1 / TH-2 Tap Handles

Made for the rigors of everyday shop use, these adjustable tap handles fit most common bicycle taps, including all Park Tool Frame and Pedal taps.

- **TH-1:** Fits most metric taps from M1.6-M8  
Fits most standard taps from #0-5/16"
- **TH-2:** Fits most metric taps from M4-M12  
Fits most standard taps from #8-9/16"

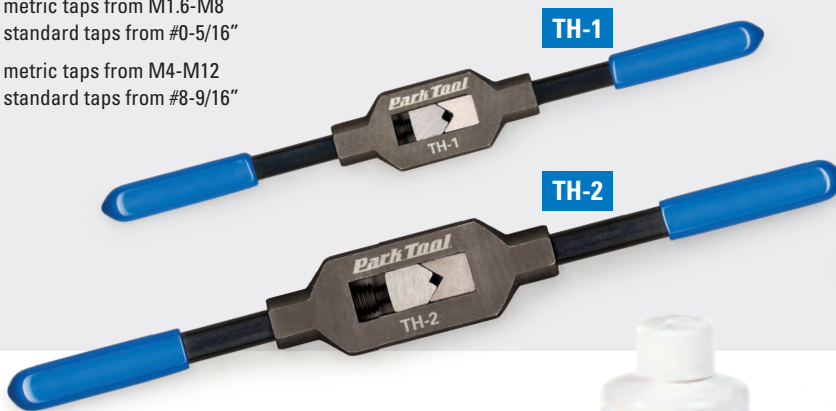

## E. CF-2 Cutting Fluid

The use of cutting oil or cutting fluid is extremely important when performing any cutting, tapping, facing, or reaming operation. Park Tool Cutting Fluid is a high quality, environmentally safe cutting fluid that extends tool life and makes any frame prep job easier and safer. Park Tool Cutting Fluid can effectively be used on all metals.

8 oz. (237 mL) bottle

## E. CF-2



## A. HTR-1



## B. HTR-1B





**A. BTS-1**

**A. BTS-1 Bottom Bracket Tapping & Facing Set**

The BTS-1 is a precision tool system which provides a piloted means of tapping the threads in the bottom bracket shell of a frame. After tapping, the taps act as guides to keep the included facing cutter perfectly square with the axis of the bottom bracket for cleanup of the faces of the bottom bracket shell. The BTS-1 includes English taps, 1.370" x 24 TPI right hand thread for the adjustable cup, and 1.370" x 24 TPI left hand thread for the fixed cup. Italian thread taps, 36mm x 24 TPI right hand thread, for the adjustable and fixed cups are available as accessories.

**Individual replacement cutters available for BTS-1:**

- #691 1.370" x 24 TPI Right Hand Tap - English
- #692 1.370" x 24 TPI Left Hand Tap - English
- #693 36mm x 24 TPI Right Hand Tap - Italian (2 required)
- #690 45mm Facing Cutter

**B. BFS-1 Bottom Bracket Facing Set**

The Bottom Bracket Facing Set is designed to be a complete self-contained facing set, combining top quality precision parts with ease of use. Simply install the threaded inserts using the facer handle, then insert the facing tool through the guides and install the tension spring and speed nut. After applying a liberal amount of cutting oil, the BFS-1 easily cuts the shell material, giving you a clean, faced surface. Now you're ready to install the bottom bracket.

**Replacement parts:**

- #690 Facer
- #688 36mm x 24 TPI right hand bushing (Italian)



**B. BFS-1**



C. FFS-2



### C. FFS-2 Frame, Fork, and Tube Straightener

The Park Tool Frame, Fork and Tube Straightener is a versatile and productive tool. The open hook design enables it to straighten not only frames and forks, but also cranks and handlebars. Vinyl coating on the hook and on the Fulcrum® pad protects painted surfaces. The hook has over 8" of adjustment. Reinforced to prevent flexing. The adjustable hook now accommodates a fork or tube up to 1-3/4" (44mm) in diameter – 35% larger than that of the FFS-1 – and features over 8" (20.3 cm) of sliding travel adjustment.

D. FFG-2



### D. FFG-2 Frame & Fork End Alignment Gauge Set

Improperly aligned frame and fork dropouts can cause bent axles and quick release skewers, as well as tracking and shifting problems. The FFG-2 quickly determines whether dropouts are aligned and parallel. If an error is detected, long handles and comfortable molded grips afford plenty of leverage for straightening. Works on frames and forks with dropout spacing up to 160mm.

E. DAG-2

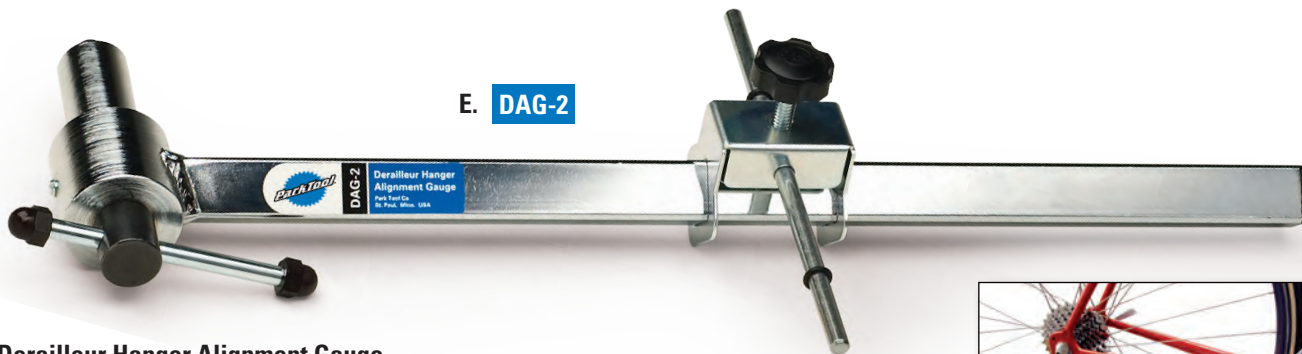

### E. DAG-2 Derailleur Hanger Alignment Gauge

The Derailleur Hanger Alignment Gauge can help solve a multitude of derailleur shifting problems, most notably with index shifting systems. The DAG-2 utilizes a longer measuring pointer, longer threaded stud and a longer, narrower alignment boss to fit a wider variety of bikes. This tool is extremely steady in operation and is simple to use. The tool threads directly into the derailleur hanger. The gauge bar holds a gauge which marks the distance to the wheel. The gauge then is rotated with the wheel to the 3, 6, 9, and 12 o'clock positions, noting any differences in measurements. The alignment of the derailleur hanger is accomplished by applying pressure to the tool's arm. The results can be checked instantly. The DAG-2 is made of heavy-gauge steel and is chrome plated for long shop life.



### F. FAG-2 Frame Alignment Gauge

Many bicycles will not shift or track properly because the front and rear wheels are not in line with the frame. If these conditions still exist after wheel and derailleur adjustments, the seat stays, chain stays, and rear drop-outs of the frame may be misaligned. For years the accepted method to check the alignment of the rear drop-out was to run a string on either side. This method does work to some extent. However, it is not accurate because the measurement is not taken at the drop-out. With the Park Tool Frame Alignment Gauge the alignment can be checked quickly and accurately at the drop-out. Retractable pointer to fit all sizes and types of bicycles.

F. FAG-2



A. SG-6



**A. SG-6 Threadless Saw Guide**

The SG-6 Threadless Saw Guide ensures a straight, clean cut on 1", 1-1/8", and 1-1/4" threadless forks. Simply clamp the SG-6 onto the fork and cut, letting the SG-6 guide the hacksaw blade. The SG-6's non-scratching composite body incorporates steel threads and a steel reinforcing plate to withstand the rigors of heavy shop use.



B. SG-7.2



**B. SG-7.2 Oversized Adjustable Saw Guide**

Accurately guides a hacksaw to cut steerers, integrated seat posts and even airfoil shaped seat posts up to 3.5" (89mm) or round tubes from 1-1/4" (32mm) to 1-3/4" (45mm) in diameter. The SG-7.2 features two different cutting slots – standard and carbon cutting blade widths – in a hardened steel body and molded contact points to protect tubes and frames.



SG-1 • SG-2

**C. SG-1 / SG-2 Threaded Saw Guides**

Cut any fork quickly and easily with these handy fork stack cutting guides. Heat treated for long life, each guide cleans the freshly cut threads upon removal so headset parts install easily. Cut as little as 1mm from any fork.

- SG-1: 1" cutting guide
- SG-2: 1-1/8" cutting guide

D. SAW-1



**D. SAW-1 Hacksaw**

All aluminum die cast frame construction, blade tension adjuster and comfortable handle make this the perfect hacksaw for the shop. SAW-1 includes one blade and accepts any 12" (300mm) hacksaw blade.



E. CSB-1

**E. CSB-1 Carbon Cutting Saw Blade**

12" Tungsten steel hacksaw blade specially designed to smoothly cut carbon composite handlebars, forks, seat masts and integrated seat posts. Fits Park Tool SAW-1 and most 12" hacksaws.



F. SG-8



**F. SG-8 Saw Guide for Carbon Composite Forks**

Similar to the SG-6 but specially designed to accommodate wider, carbon composite specific saw blades.

### G. RT-1 / RT-2 Head Cup Remover

The Park Tool Head Cup Remover makes headset cup removal easy. The tool is pulled through the frame until the flared ends snap in behind the cup. A blow on the tool head removes the cup. Strong, heat treated alloy steel with nickel finish.

- **RT-1:** Fits 1", 1-1/8", 1-1/4" as well as some low profile and internal head cups.
- **RT-2:** Fits 1-1/4" and 1-1/2" head cups as well as some low profile and internal head cups.



(Fig-1)



(Fig-2)

### H. HHP-2 Bearing Cup Press

The HHP-2 accurately aligns and presses 1", 1-1/8", 1-1/4", and 1.5" headset cups. In addition, it presses cartridge bearings and cups into one-piece bottom bracket shells (Fig-1) and holds fixed cup wrenches firmly in place when removing or installing adjustable-type bottom brackets (Fig-2). Features a quick-release design for fast tool installation and removal, extra long (30cm) handles for superior leverage, and stepped bushings for precise cup alignment.



H. HHP-2

### I. 530-2 Step Bushing Cup Adaptors

Included with HHP-2, also available separately in pairs.



J. HHP-3

### J. HHP-3 Home Mechanic Head Cup Press

Simple and economical, the HHP-3 is designed to install all sizes of head cups and one-piece bottom bracket cups.



K. FTS-1

### K. FTS-1 Fork Threading Set

The FTS-1 Fork Threading Set is designed for cutting new threads and for chasing existing threads on fork columns that are not chromed. The FTS-1's expandable cutting dies are made from the highest quality high speed steel for precision cutting and long life. The unique thread guide system used with the FTS-1 is specially designed to allow the metal chips and shavings that result during use to fall completely through the guide, preventing damage to the fork threads and the tool. The FTS-1 includes die handles, 1" x 24 tpi cutting die (Part #606), and 1" cutting guide (Part #610). 1-1/8" x 26 die (Part #607), 1-1/4" x 26 die (Part #608), 1-1/8" guide (Part #611), and 1-1/4" guide (Part #612) are available as accessories. Die handles fit all three sizes of dies and guides.



A. CRC-15



### A. CRC-15 Crown Race Cutter Adaptor

Used in conjunction with the CRC-1 Crown Race Cutting Tool to machine 39.8mm crown race seats (1.5" standard) on tapered forks with 1-1/8" steerer tubes. Includes precision-machined adaptor body and 39.8mm high-speed steel crown race cutter.

B. CRC-1



### B. CRC-1 Crown Race Cutting Tool

To ensure proper headset performance and longevity, special attention must be given to accurately machine the fork's crown race seat. The CRC-1 is a professional quality machining tool for milling both the outer edge and lower surfaces of the crown race seat. A unique adjusting system allows a tight fit of the tool on any fork, threaded or unthreaded (even forks with externally butted steerer tubes), ensuring a smooth, accurate cut and proper alignment of the fork in the frame. The CRC-1 Crown Race Cutting Set includes high speed steel cutters and adjustable collets to machine 26.5mm and 27.1mm crown race seats on 1" forks and 30.1mm crown race seats on 1-1/8" forks.



C. CRP-2



### C. CRP-2 Adjustable Crown Race Puller

The CRP-2 is a precision tool for quickly and easily removing the headset crown race from the crown race seat of the fork. The tool is fully adjustable, allowing precise, independent positioning of the blades around the crown race. Locating each blade independently provides flexibility to fit around most potential interferences with fork top caps or crown protrusions.

- Universal design works with 1", 1-1/8", 1-1/4" and 1.5" forks (suspension or rigid) and crown races with outside diameters up to 64mm.
- Accepts steering columns up to 430mm in length
- All-steel construction for long life

**Note:** Blades are necessarily thin and will wear with use. Crown races with a tight press fit may also wear on blades.

Replacement blades are available: Part #1155-3

HCW-15



HCW-9

HCW-7

HCW-6

### D. HCW-6 / HCW-7 / HCW-9 / HCW-15 Headset Wrenches

Our popular and versatile Head Wrenches feature our proven "Y" head design and all headset wrench openings are laser cut to ensure a tight, accurate fit. Precise sizing is achieved by high voltage computer controlled lazer technology after heat-treat. Waiting until the wrench is heat treated eliminates shrinkage and expansion of the steel after the wrench is sized. It takes longer, and costs more, but it's worth the extra effort.

- **HCW-6:** 32mm head wrench & 15mm pedal wrench
- **HCW-7:** 30mm & 32mm head wrench
- **HCW-9:** 36mm & 40mm head wrench
- **HCW-15:** 32mm & 36mm head wrench



E. CRS-1

Replacement inserts

**E. CRS-1 Crown Race Setting System**

We've taken a fresh new approach to crown race installation. Traditionally, a mechanic would slam a tube down onto the bearing surface to "set" the race in place. The CRS-1 offers a different approach that offers faster, safer, and more precise installation. The bearing surface is spared a direct hit by using different inserts to ensure proper fit on the race. Choose the correct insert then slide the tube over the fork tube and into the top end of the insert. Using a hammer, tap firmly on the end cap of the tube and seat the race into its proper place safely and accurately. The CRS-1 set includes one universal setting tube, three 1" inserts, and three 1-1/8" inserts.



F. CRS-15

**F. CRS-15 Crown Race Setting System for 1.5" and 1-1/4"**

Includes setting tube, one 1.5" setting insert, and one 1-1/4" setting insert.

**Replacement parts:**

- #827 1.5" setting insert
- #821 1-1/4" setting insert

G. TNS-1 • TNS-15



**G. TNS-1 / TNS-15 Threadless Nut Setter**

The Threadless Nut Setter is used to install the star-fangled nut found on threadless headset systems. Thread the nut onto the TNS, insert into the fork stack, and tap it in with a hammer. Sets the star-fangled nut to 15mm and keeps it straight. Long handle helps prevent pinched fingers.

- **TNS-1:** 1" and 1-1/8" Headset systems
- **TNS-15:** 1-1/4" and 1.5" Headset systems

Uses Part #822 Replacement Set Screws.



star nuts not included

H. TNS-4



**H. TNS-4 Deluxe Threadless Nut Setter**

The TNS-4 makes it quick and easy to install star-fangled nuts used with 1" and 1-1/8" threadless headset systems. Using a durable steel driver and built-in guide, the TNS-4 perfectly aligns the star-fangled nut and sets it to the proper depth every time. The unique design virtually eliminates pinched fingers.

Uses Part #822 Replacement Set Screws.



A. ES-1

### A. ES-1 Event Stand

A versatile, stable, multi-purpose storage rack built to hold up to twelve bikes by the nose of the saddle. Perfect for events, races or sidewalk storage the ES-1 disassembles and folds easily for compact storage. The ES-1 is roughly eight feet long but can be extended in length with the use of ES-2 Add-on Kits.

**Includes:**

- 2 – Height adjustable tripod uprights
- 2 – 47" (119cm) support tubes (96" (239cm) total length)
- 1 – Connector sleeve



B. ES-2

### B. ES-2 Event Stand Add-on Kit

**Includes:**

- 1 – Height adjustable tripod upright
- 2 – 47" (119cm) support tubes
- 1 – Connector sleeve



C. PB-1



### C. PB-1 Portable Workbench

Perfect for taking to races and rides, the PB-1 is a workbench that folds for easy transport and storage. Features a large 36" x 23" work surface (91.5cm x 58.5cm) with specially sized slots, holes, and ports for holding tools, shop towels, lubes, and accessories (such as the PTH-1 Paper Towel Holder). Heavy duty steel legs provide a rock solid base for heavy tools and supplies.

**Folded:** 42.5" x 23" x 7"  
(108cm x 58.5cm x 18cm)

**Set Up:** 36" x 23" x 32.5"  
(91.5cm x 58.5cm x 82.5cm)



G. **JH-1**

### G. JH-1 Bench Top Small Parts Holder

A great place to keep small parts, cable end caps, grease, and whatever else you can think of. Stainless steel construction with a clear acrylic hinged top and four removable bins. 12" x 5.5" x 3.5" (30.5cm x 14cm x 9cm)



I. **MB-1**

### I. MB-1 Magnetic Parts Bowl

This bench top accessory keeps small parts accessible and all in one place. 6" (15cm) in diameter and featuring an extra strong magnet, the MB-1 is available only in world famous Park Tool Blue.

### H. OM-1 Benchtop Overhaul Mat

A great way to hold small parts, tools and components during a repair, the OM-1 features multiple small pockets and one large work area. Perfect for suspension work or to organize parts for installation. Made of a rubber-like PVC, the OM-1 cleans easily and looks great on any bench. Measures: 13.4" x 9.4" (34cm x 24cm)



H. **OM-1**

Park Tool introduced the original storage hook over forty years ago! Available in both wood threaded and machine threaded versions, these hooks are made of strong steel wire and are vinyl coated for long, scratch-free life.

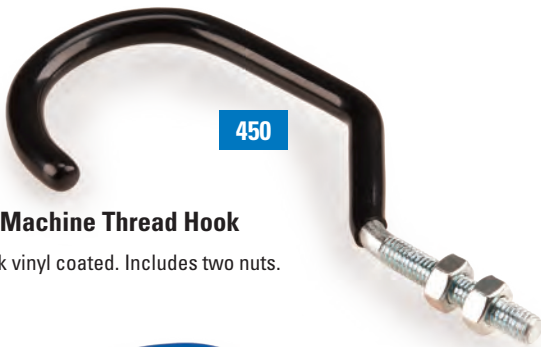

450

### 450 Machine Thread Hook

Black vinyl coated. Includes two nuts.



470

### 470 Oversize Machine Thread Hook

Black vinyl coated. Includes two nuts.



451

### 451 Wood Thread Hook

Blue vinyl coated.



471

### 471 Oversize Wood Thread Hook

Blue vinyl coated.



A. PZT-2

**A. PZT-2 Pizza Tool**

What's better than pizza after a good day of wrenching or riding? An update of one of our all-time greats, the PZT-2 Pizza Tool is bigger (for better hand position), better (super sharp, large diameter stainless steel cutting wheel cuts through even the toughest terrain), and stronger! Amaze your friends, show off to your in-laws. It's a bicycle...it's a pizza cutter!



D. PNT-1  
Pint Glass



E. BO-5

**E. BO-5 Wall Mount Bottle Opener**

Cleverly disguised as a water bottle cage the BO-5 attaches to any wall, workbench or cabinet and features a handy water bottle style cap catcher.



B. SPK-1

**B. SPK-1 Spork**

It's a spoon, it's a fork, it's a take along multi tool. Made of 316 food grade stainless steel and vinyl dipped in world famous Park Tool Blue. Dishwasher safe.



C. BO-2

**C. BO-2 Bottle Opener**

The ergonomically designed BO-2 is engineered and built to provide tremendous leverage, making quick work of any bottle cap. World famous Park Tool blue vinyl coated handle and stainless steel construction provide years of comfortable use. Dishwasher safe.



F. BO-3



**F. BO-3 Key Chain Bottle Opener**

A compact opener featuring our world famous blue handle and a 10mm wrench. Fits perfectly on a keychain or in a pocket or wedge pack. A take along tool you shouldn't be without.





**G. HAT-4** Park Tool Ball Cap



**H. MUG**  
Coffee Mug



**I. STL-1.2**

### I. STL-1.2 Shop Stool

The STL-1.2 Park Tool Shop Stool has chrome-plated steel legs and a comfortable padded seat with a three-color Park Tool Logo. The seat swivels 360 degrees and is positioned at a height of 32" (81cm)—the perfect height for wheel truing or other work at a bench or counter. Great in the shop or on the sales floor. Add the STL-3K Stool Back Kit to convert the STL-1.2 into a stool with a padded back rest.

### J. STL-2 Rolling Adjustable Height Shop Stool

The STL-2 is ideal for quickly maneuvering around the bike while making adjustments. It has an adjustable gas shock with 5" (13cm) of travel, smooth-rolling wheels, and a swiveling seat with a three-color Park Tool Logo. Adjusts in height from 17" to 22" (44cm to 57cm).



**J. STL-2**



**K. STL-3K**

### K. STL-3K Shop Stool Back Rest Kit

Turns an STL-1.2 into a stool with a padded back rest.





**A. GLV-1**

**A. GLV-1 Mechanic's Gloves**

Great for riding, mechanical work or to just show off the colors of your favorite tool brand, the GLV-1 is the perfect combination of comfort and function.

**Features:**

- Digital Amara® palm with anatomically shaped external reinforcement patches
- Touch phone compatible thumb and index fingertips
- Comfortable and soft fleece brow wipe
- Durable two-way stretch knit glove back with knuckle gussets
- TPR adjustable closure tab
- Sizes: S, M, L, and XL



**B. SWH-3**

**B. SWH-3 Hoodie Sweatshirt**

This pullover hoodie with embroidered patch is a heavyweight when it comes to keeping you warm and a testament to your good taste when it comes to style (and bicycle tools).

Sizes S, M, L, XL, and XXL



**C. TSW-1**

**C. TSW-1 Park Tool T-Shirt**



**D. MS-1**

**D. MS-1 Mechanic's Shirt**

The MS-1 Mechanic's Shirt is an oversized version of the traditional mechanic's shirt. It has two pockets and is made from a wrinkle-free 65% poly/35% cotton blend for long wear and good looks. Black with Park Tool logo.

Sizes M, L, XL, and XXL

**E. SA-3**



**E. SA-3 Heavy Duty Shop Apron**

Once you try on this apron, there's no going back to standard aprons. The SA-3 is made from heavy 10 oz. cotton canvas and has two rows of bar tack reinforced pockets for stashing pens, parts, tools, etc. The special crossback design removes pressure from the neck for all day comfort. A nylon quick release makes the apron easy to adjust and take off. A full 35" in length, the bottom 7" of the apron can be snapped up for a custom height fit. A Park Tool logo makes the apron as good looking (even when it's dirty) as it is functional.

**F. SA-1**



**F. SA-1 Shop Apron**

Protect your clothes and gain the advantage of large pouch pockets whenever you work in the shop. Our full-length, shop quality aprons are made of a heavy 7-ounce cotton twill for comfort and durability. Navy blue with white Park Tool logo.

**Includes tool selection guide**

Circular base is 30-inches (76.2 cm) in diameter, and the unit stands 70-inches (1.778 m) tall.



**A. PDR-4**



2 - PFP-8 included

**A. PDR-4 Park Tool Display System**

"The Right Tool for the Job". Over 4,000 bike shop owners worldwide rely on Park Tool Displays to help sell tools. A great mix of tools for maintaining most bikes, attractive packaging and graphics, a copy of our Home Mechanic Tool Selection Guide, and a versatile display that can be easily rolled from one location in the shop to another. It all adds up to create an impressive, well-defined tool and information center that sends your customers the message they've come to the right place for all their bicycle tool needs. If you're serious about selling bicycle tools, the PDR-4 Park Tool Display System is the right tool for the job.

**B. PDR-6**



**B. PDR-6 Double Wall Display**

The PDR-6 showcases a selection of popular tools on two display panels. Easily mounts side-by-side or vertically to any wall.

Two wall units measure 23-inches (58.4 cm) wide and 46-inches (1.168 m) tall each. Total display is 46-inches by 46-inches.

**C. PDR-5**



Wall unit measures 23-inches (58.4 cm) wide and 46-inches (1.168 m) tall.

**C. PDR-5 Mini Wall Display**

If you don't have the space for a full display system, check out the PDR-5 Mini Wall Display. It's a great way to get your feet wet and to discover how profitable selling tools can be.